



City of Peru

JAMEY MERTEL
CITY CLERK

P.O. Box 299 • 1901 Fourth Street • Peru, IL 61354-0299
815-223-0061 • www.peru.il.us

AGENDA

REGULAR CITY COUNCIL MEETING

MONDAY, OCTOBER 20, 2025

RESIDENTS ARE WELCOME TO WATCH THE MEETINGS LIVE ON OUR
YOU TUBE CHANNEL AT [City of Peru, Illinois - YouTube](#)

ROLL CALL

7:00 P.M.

PLEDGE OF ALLEGIANCE

PUBLIC COMMENT

PRESENTATION

MINUTES/FINANCIAL REPORTS/ACTIVITY REPORTS

REGULAR MEETING MINUTES OF OCTOBER 6, 2025

TREASURER'S REPORT FOR SEPTEMBER 2025

CITY CLERK'S REPORT OF CASH RECEIVED FOR SEPTEMBER 2025

COMMITTEE REPORTS

1. FINANCE COMMITTEE-Chairman, Alderman Payton. Members, Aldermen Tieman, Sapienza, Ballard

DISBURSEMENTS for October 22, 2025

Motion to authorize 2026 property casualty and workman's compensation insurance with IMLRMA in the amount of \$446,543.56.

2. PUBLIC SERVICES COMMITTEE-Chairman, Alderman Edgcomb. Members, Tieman, Payton, O'Sadnick

Motion to approve quote from Illinois Valley Fence and Pool Inc for \$30,000 for Washington Park Happ Field

Discuss hiring a patrol officer

3. PUBLIC WORKS COMMITTEE-Chairman, Alderman Lukosus. Members, Aldermen Ballard, Sapienza, Moreno

Motion to authorize the Electric Department to seek quotes for 65' & 70' Class 1 wood power poles.

Approve the purchase of accessories for the new bucket truck from Custom Truck One Source in the amount of \$28,792.00

REPORT OF CITY ATTORNEY/ORDINANCES AND RESOLUTIONS

MINUTES OF THE OCTOBER 15, 2025, PLANNING AND ZONING COMMISSION HEARING HELD ON THE PETITION OF THE CITY OF PERU SEEKING APPROVAL OF FINAL PLAT OF HALM SUBDIVISION

AN ORDINANCE APPROVING AND ACCEPTING THE FINAL PLAT OF HALM SUBDIVISION TO THE CITY OF PERU AS SOUGHT BY THE PETITION OF THE CITY OF PERU, ILLINOIS

MINUTES OF OCTOBER 15, 2025, PLANNING AND ZONING COMMISSION HEARING HELD ON THE PETITION OF SABAS ORALDO MADERA AND ANA ROSA MADERA CONCERNING PROPERTY LOCATED AT 2404 PLUM STREET

AN ORDINANCE GRANTING A SPECIAL USE AND VARIANCE AS SOUGHT BY THE PETITION OF SABAS ORALDO MADERA AND ANA ROSA MADERA CONCERNING PROPERTY LOCATED AT 2404 PLUM STREET IN THE CITY OF PERU

MINUTES OF OCTOBER 15, 2025, PLANNING AND ZONING COMMISSION HEARING ON THE PETITION OF KEVIN MATEIKA AND JESSICA MATEIKA CONCERNING PROPERTY LOCATED AT 2103 MAIN STREET

AN ORDINANCE GRANTING A SPECIAL USE AND VARIANCE AS SOUGHT BY THE PETITION OF KEVIN AND JESSICA MATEIKA CONCERNING PROPERTY LOCATED AT 2103 MAIN STREET IN THE CITY OF PERU

AN ORDINANCE AUTHORIZING THE ACCEPTANCE OF A PUBLIC UTILITY EASEMENT FROM PERU INDUSTRIAL RAILROAD, LLC (Peru Rail f/k/a LaSalle & Bureau County Railway, Peru – GIS PIN: 11-32-502-001)

AN ORDINANCE DECLARING A CERTAIN POLICE DEPARTMENT SQUAD CAR AS SURPLUS PROPERTY AND AUTHORIZING THE SALE THEREOF

PROCLAMATIONS

UNFINISHED BUSINESS

NEW BUSINESS

PETITIONS AND COMMUNICATIONS

ITEM NO. 1 Communication from Michael Blaydes seeking variances/waivers from the Zoning Ordinance for the property located at 1420 Peoria Street.

ITEM NO. 2 Communication from City Center Rehabilitation requesting permission to host a 5K run/walk in the City of Peru on June 20, 2026, with proceeds going to Illinois Valley Food Pantry

MAYOR'S NOTES

PUBLIC COMMENT

CLOSED SESSION

ADJOURNMENT

CITY OF PERU REGULAR COUNCIL MEETING OCTOBER 6, 2025

A regular meeting of the Peru City Council was called to order by Mayor Ken Kolowski in the Peru City Council Chambers on Monday, October 6, 2025, at 7:00 p.m.

City Clerk Jamey Mertel called the roll with Aldermen Ballard, Tieman, Payton, Edgcomb, Sapienza, O'Sadnick, Lukosus and Moreno present. Mayor Kolowski present.

PRESENTATION

Ms. Tara Backes, Athletic Director for Parkside Middle School spoke on the Parkside Boys Baseball team placing 2nd in state. Head Coach Christian Parry spoke on two months of non-stop baseball and the dedication of the boys and the parents.

PUBLIC COMMENT

Ms. Judy Terando stated her grandkids have outgrown the splash pad-stating she voted for the pool and knew what she was voting for.

Mr. George Marple stated the proposed pool does not make good economic sense.

Ms. Jennifer Ebner stated she is in favor of a pool and the city officials need to listen to their constituents.

Ms. Maureen Rebholz stated that although the proposed pool would only be open a short amount of time, 3 months to a child is forever. Ms. Rebholz stated we all have fond pool memories and encouraged the council to vote in favor of the pool.

Mr. Keto Matos spoke in favor of a pool and stated you cannot put a price on memories. Mr. Matos stated many of his childhood memories were at a pool.

Ms. Carrie Helmig reported on fond memories she had with her late brother at the old pool. Ms. Helmig stated former mayor Scott Harl closed the pool and scolded the Aldermen for letting it happen. Ms. Helmig stated that LP doesn't teach swimming lessons and parents cannot afford lessons at the YMCA.

Mr. Larry Huffman reported that the U of I research lab would say the question on the ballot was not a true vote of the community. Mr. Huffman stated that he has been on boards where we had to make an unpopular decision, however, the council knows more about city finances than the public does.

Mr. Michael Ladzinski stated we have grown wary of politicians, noting the State of IL is broke, but the city found money for new city hall and police station.

Ms. Crystal Dean addressed the council with her 7 yr old and 4 yr old and stated they learned how to swim by taking lessons at the LaSalle pool. Ms. Dean stated they would really like a pool.

Mr. Glen Flodstrom reported that in 2008, he purchased his home because it was in the vicinity of the pool, school and library. Mr. Flodstrom stated his children are grown now but still in support of a pool.

Mr. Martin Rue stated he lived on Plain Street his entire life. Mr. Rue stated the council had a special meeting before the vote and we knew what they were voting for.

CITY OF PERU REGULAR COUNCIL MEETING OCTOBER 6, 2025

Mr. Matt Rebholz reported he purchased his home because it was in close vicinity to the pool and stated he believes kids need to learn how to swim.

Mr. Eric Solderholm stated the city needs a pool and stated the council has financial knowledge but 70% of the vote (advisory referendum) said they were in favor of the pool. Mr. Solderholm stated the proposed pool wouldn't be for the past memories, but for future memories for more than just children.

Ms. Janet Mayszak stated she is a life-long resident of Peru and want future memories [of pool]. Ms. Mayszak stated the city needs a pool, the constituents voted in favor of it, and to please honor what the constituents voted for.

MINUTES/FINANCIAL REPORTS/ACTIVITY REPORTS

Mayor Kolowski presented the Regular Minutes of September 2, 2025, and Building Permits-Third Quarter Report 2025. Alderman Payton made a motion the minutes and reports be received and placed on file. Alderman Lukosus seconded the motion; motion carried.

FINANCE AND SAFETY COMMITTEE

Alderman Sapienza presented the following disbursements for payment on October 8, 2025:

<u>FUND NAME</u>	<u>TOTAL EXPENSES</u>
General Fund	\$440,954.22
Insurance Fund	150,519.43
Garbage Fund	81,145.28
MVP TIF	166.00
Utility Fund	1,025,760.59
Landfill Fund	4,514.20
Airport Fund	<u>4,833.50</u>
Total	\$1,707,893.72

Alderman Sapienza made a motion the disbursements be received, placed on file and bills paid in the usual manner. Alderman Tieman seconded the motion. Clerk Mertel called the roll with Aldermen Ballard, Tieman, Payton, Edgcomb, Sapienza, O'Sadnick, Lukosus and Moreno voting aye. Motion carried.

PUBLIC SERVICES COMMITTEE

PSM/Fire Chief reported the burn ban is still in effect.

Adam Thorson, Director of Parks, Recreation and Special Events reported on the Chicago Blue's night on Saturday, October 11th in Centennial Park. Mr. Thorson stated the Peru CSO will be serving food.

Alderman Edgcomb made motion to accept and proceed with the September 19, 2025, proposal from Kmetz Architects to the City of Peru to provide Full Architectural & Engineering services for a proposed

CITY OF PERU REGULAR COUNCIL MEETING OCTOBER 6, 2025

Municipal Swimming Pool to be located in the vicinity of Washington Park. (on an 8.75% percentage of the final construction cost). Alderman O'Sadnick seconded the motion.

Alderman Edgcomb stated he spent a lot of time thinking and the majority of emails he received were to vote no on the pool. Alderman Edgcomb stated that he said from the beginning that if the people voted for it, he would support it even though most people do not support it.

Alderman Payton stated that for 11 years he's shown the city cannot financially support a pool. Alderman Payton stated the hotel/motel tax doesn't create enough money to pay for a pool. Alderman Payton stated he asked Mayor Kolowski to wait on proceeding with the motion but here we are.

Alderman Tieman stated that he received numerous calls regarding the proposed pool and noted the \$185 million in water treatment upgrades coming in the next 10 years and right now is not the right time to spend this amount of money. Alderman Tieman stated he asked Alderman O'Sadnick to delay this vote but here we are.

Alderman Ballard stated he voted for a pool 3 years ago but since then, things in the city have changed. Alderman Ballard also noted the 13% reduction request in budget a few months ago.

Alderman Sapienza reported on the collaboration with the YMCA to provide swim lessons free of charge to Peru residents. (Fee paid up front and reimbursed upon completion of course). Alderman Sapienza also stated that he promised to do his best for the City of Peru.

Alderman Lukosus stated he cannot support the proposed pool as our finances are not in shape. Alderman Lukosus noted the street program was scaled back, to which only 2 blocks in the 4th Ward will be addressed.

Alderman O'Sadnick stated he would be voting yes but asked everyone to be respectful of the vote no matter how it turned out.

Alderman Moreno asked that after tonight's vote, please leave the police station in the past,

Mayor Kolowski provided the following thoughts:

- The public said to do it
- The city can afford it
- If done in 2015, we would be finishing up the payments on it
- I cut the budget, aldermen voted on it. Cut waste from budget
- If pool was approved in 2015, there's a chance he would not have run for mayor, but kicking the project down the curb only makes the project more expensive
- Appreciated all opinions
- Millions of dollars spent upgrading parks

Aldermen Edgcomb and O'Sadnick voting aye; Aldermen Ballard, Tieman, Payton, Sapienza, O'Sadnick, and Moreno voting nay. Motion denied

PUBLIC WORKS COMMITTEE

Alderman Ballard made a motion to approve a bid from John Pohar & Sons for the EAKAS watermain extension in the amount of \$\$679,383.08. Alderman Lukosus seconded the motion. Clerk Mertel called the

CITY OF PERU REGULAR COUNCIL MEETING OCTOBER 6, 2025

roll with Aldermen Ballard, Tieman, Payton, Edgcomb, Sapienza, O'Sadnick, Lukosus and Moreno voting aye. Motion carried.

Alderman Sapienza made a motion to approve a design-build proposal from John Pohar & Sons for the mass grading of the 138kv Substation development. Alderman Moreno seconded the motion. Eric Carls, Director of Engineering and Zoning, reported the city added a reserve account for this project be needs to start immediately. Mr. Carls reported this project is in conjunction with the Ameren open houses and noted his has been talked about for a long time. Alderman Sapienza stated the city has been working on this project for 30 years. Mr. Carls noted the new substation will double our megawatts and the city is at capacity. Mr. Carls stated that it is not in the budget but that is why we have reserves. Mr. Carls also noted we have turned down development because we don't have the capacity. Mr. Carls also stated the 138kv will also cut down our cost of power. Alderman Edgcomb stated that Electric Operations Manager Kevin Minnick also noted this will reduce the cost to the customers going forward. Clerk Mertel called the roll with Aldermen Ballard, Tieman, Payton, Edgcomb, Sapienza, O'Sadnick, Lukosus and Moreno voting aye. Motion carried.

Alderman Moreno made a motion to approve a change order with Performance Pipelining, Inc. for the Interceptor Sewer Cleaning & TV Inspection in the amount of \$68,421.00. Alderman Lukosus seconded the motion. Alderman Edgcomb noted the company has the relining capabilities if needed. Clerk Mertel called the roll with Aldermen Ballard, Tieman, Payton, Edgcomb, Sapienza, O'Sadnick, Lukosus and Moreno voting aye. Motion carried.

Alderman Lukosus made a motion to approve a repair and maintenance invoice for \$22,798.81 payable to Continental Blower to replace a blower that failed. Alderman Sapienza seconded the motion. Chris Perra, President of T.E.S.T. reported this blower is located at the WWTP. Clerk Mertel called the roll with Aldermen Ballard, Tieman, Payton, Edgcomb, Sapienza, O'Sadnick, Lukosus and Moreno voting aye. Motion carried.

REPORT OF CITY ATTOREY/ORDINANCES AND RESOLUTIONS

Corporate Counsel Scott Schweickert presented a proposed ordinance entitled:

ORDINANCE NO. 6984

AN ORDINANCE AMENDING CHAPTER 22 – BUILDINGS AND BUILDING REGULATIONS OF THE CITY OF PERU CODE OF ORDINANCES AS IT RELATES TO THE REGISTRATION OF RENTAL RESIDENTIAL PROPERTY

Alderman Tieman made a motion the ordinance be adopted as written and read. Alderman Sapienza seconded the motion. Clerk Mertel called the roll with Aldermen Ballard, Tieman, Payton, Edgcomb, Sapienza, O'Sadnick, Lukosus and Moreno voting aye. Motion carried.

Corporate Counsel Scott Schweickert presented a proposed ordinance entitled:

ORDINANCE NO. 6985

AN ORDINANCE EXECUTING A RE-DEVELOPMENT AGREEMENT WITH POJO LIMITED PARTNERSHIP FOR PROPERTY LOCATED AT 1840 MAY ROAD

CITY OF PERU REGULAR COUNCIL MEETING OCTOBER 6, 2025

Alderman Edgcomb made a motion the ordinance be adopted as written and read. Alderman S seconded the motion. Clerk Mertel called the roll with Aldermen Ballard, Tieman, Payton, Edgcomb, Sapienza, O'Sadnick, Lukosus and Moreno voting aye. Motion carried.

PROCLAMATIONS

UNFINISHED BUSINESS

NEW BUSINESS

PETITIONS AND COMMUNICATIONS

Clerk Mertel presented a communication from Insanity Haunted House requesting permission to place temporary signage until November 8th, 2025. Alderman Tieman made a motion the communication be received, placed on file and permission granted. Alderman Sapienza seconded the motion. Motion carried.

Clerk Mertel presented a communication Merry Noonan requesting permission to close off 5th Street in front of Lou's LaGratto, on October 11th, for a "Trick or Treat" event co-hosted with Dreamwave Wrestling. Alderman Lukosus made a motion the communication be received, placed on file and permission granted. Alderman Moreno seconded the motion. Motion carried.

Clerk Mertel presented a communication from Alicia Farmer requesting permission to hold the annual Better Fishing Association Kids Fishing Expo at Baker Lake on May 9, 2026. Alderman Tieman made a motion the communication be received, placed on file, and permission granted. Alderman Ballard seconded the motion. Motion carried.

MAYOR'S NOTES

PUBLIC COMMENT

CLOSED SESSION

ADJOURNMENT

Alderman Lukosus made a motion that the meeting be adjourned. Alderman Payton seconded the motion and motion carried. The meeting was adjourned at 8:54 p.m.

CITY OF PERU

TREASURER'S REPORT

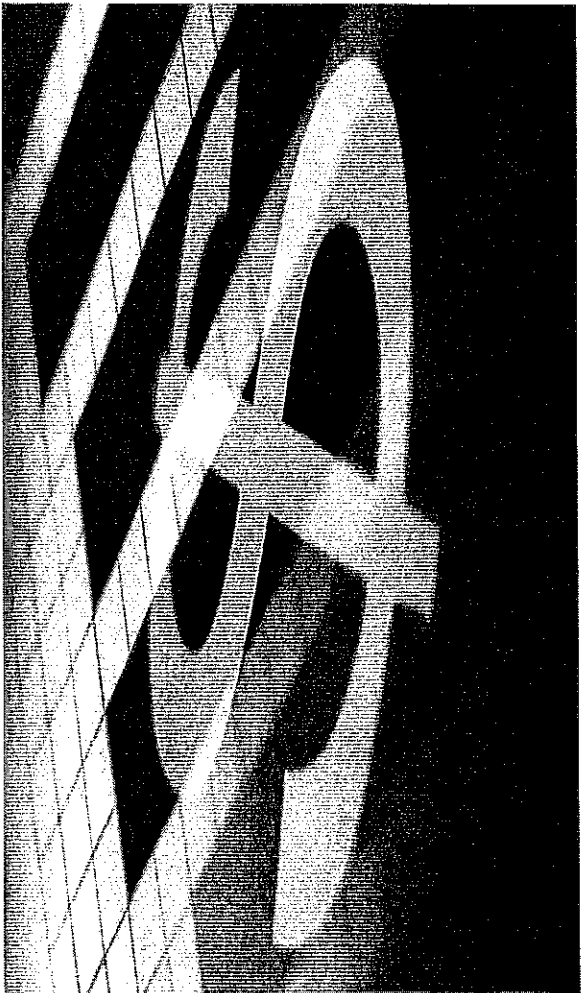

September 2025
JACKSON POWELL, TREASURER

Treasurer's Monthly Report Index

Line Item Description	Page
Combined Operating Account Status Report	6
Concentration of Deposits Report	5
Firefighters Pension Trust Fund Report of Investments	6
Fund Balances By Type	4
Fund Investments	7
Garbage Fund	2
GASB 54 Balance Use Definition Totals	4
General Fund - Bond Accounts	1
General Fund - Operating Accounts	1
Illinois Valley Regional Airport Enterprise Fund	4
Infrastructure Home Rule Sales Tax Account	1
Insurance Fund	2
Landfill Enterprise Fund	4
Motel Tax Account	1
Motor Fuel Tax Fund	2
Parkside Bond Account	1
Past Elected Officials Account	1
Peru Celebration Trust Account	1
Peru Municipal Pool Account	1
Peru Police Drug Enforcement, Impound&Equipment Fund	2
Police Pension Trust Fund Report of Assets	6
TIF Funds	2
Utility Fund - Bond Accounts	3
Utility Fund - Operating Accounts	3
Waterworks & Sewerage System Enterprise Fund	3

Treasurer's Monthly Report



Fund Description Financial Institution - Account #	Previous Period Balance	Receipts	Disbursements	Interest Earned	End of Period Balance	Balance Use Definition	Cumulative Unassigned Fund Balance	Cumulative Fund Balance
General Fund Operating Checking Account Hometown National Bank - Acct #105853	\$ 48,990.04	\$ 1,337,558.51	\$ (757,878.06)	\$ 3.07	\$ 628,673.56	Unassigned	\$ 628,673.56	\$ 628,673.56
General Fund Automatic Clearing House Account Heartland Acct #6506402	\$ 87,579.88	\$ 1,465,401.40	\$ (1,459,424.49)	\$ 162.76	\$ 93,719.55	Unassigned	\$ 722,393.11	\$ 722,393.11
General Fund Investment Account Illinois Fund - Mercantile Bank - Acct #7139166001	\$ 95,918.92	\$ 1,295,231.00	\$ (983,296.04)	\$ 1,999.41	\$ 409,853.29	Unassigned	\$ 1,132,246.40	\$ 1,132,246.40
General Fund Operating Reserve Transaction Account Illinois Fund - Mercantile Bank - Acct #4348664122	\$ (589,538.60)	\$ 524,226.02	\$ (788,714.04)	\$ -	\$ (854,026.62)	Unassigned	\$ 278,219.78	\$ 278,219.78
General Fund Operating Reserve Investments General Fund Operating Reserve CDs/MMIs	\$ 1,304,747.06	\$ -	\$ -	\$ 2,526.94	\$ 1,307,274.00	Unassigned	\$ 1,586,493.78	\$ 1,586,493.78
Farm Cash Rent Account - Hertz Management Heartland - Acct #2637	\$ 614.32	\$ -	\$ -	\$ 0.69	\$ 615.01	Unassigned	\$ 1,586,108.79	\$ 1,586,108.79
Infrastructure Home Rule Sales Tax Account Infrastructure Plank Rd Reserve	\$ 3,503,019.90	\$ 391,249.04	\$ -	\$ 26,251.97	\$ 3,920,520.91	Restricted	\$ 1,586,108.79	\$ 5,506,629.70
Infrastructure Water Tower Painting Reserve	\$ 1,555,000.00	\$ -	\$ (304,453.76)	\$ -	\$ 1,250,546.24	Restricted	\$ 1,586,108.79	\$ 6,757,175.94
Infrastructure Commercial Expansion Reserve	\$ 445,231.11	\$ -	\$ -	\$ -	\$ 445,231.11	Restricted	\$ 1,586,108.79	\$ 7,202,407.05
Infrastructure Mercantile Bank - Acct #4348664122	\$ 850,000.00	\$ -	\$ -	\$ -	\$ 850,000.00	Restricted	\$ 1,586,108.79	\$ 8,052,407.05
Motel Tax Account Motel Tax Account-OSLAD Grant Reserve	\$ 316,316.75	\$ 100,054.43	\$ -	\$ 6,241.57	\$ 422,612.75	Committed	\$ 1,586,108.79	\$ 8,475,019.80
Motel Tax Account-JTEP Grant Reserve	\$ 1,197,000.00	\$ -	\$ (479,493.05)	\$ -	\$ 717,506.95	Restricted	\$ 1,586,108.79	\$ 9,192,526.75
Peru Federal Account #161314228#162310209	\$ 500,000.00	\$ -	\$ -	\$ -	\$ 500,000.00	Restricted	\$ 1,586,108.79	\$ 9,692,526.75
Parkside Bond Obligation Reserve Illinois Fund - Mercantile Bank - Acct #4348664122	\$ 1,073,147.16	\$ 129,741.54	\$ -	\$ -	\$ 1,202,888.70	Restricted	\$ 1,586,108.79	\$ 10,895,415.45
OSLAD Grant - Washington Park Illinois Fund - Mercantile Bank - Acct #4348664122	\$ 121,978.80	\$ -	\$ (121,978.80)	\$ -	\$ -	Restricted	\$ 1,586,108.79	\$ 10,895,415.45
General Fund 2020/2021 Bond Reserve Illinois Fund - Mercantile Bank - Acct #4348664122	\$ 441,452.02	\$ 78,226.04	\$ -	\$ -	\$ 519,678.06	Restricted	\$ 1,586,108.79	\$ 11,415,093.51
Brush Truck Reserve Illinois Fund - Mercantile Bank - Acct #4348664122	\$ -	\$ -	\$ -	\$ -	\$ -	Committed	\$ 1,586,108.79	\$ 11,415,093.51
Past Elected Officials Account Peru Federal Savings - Acct #1002354591	\$ 6,827.91	\$ -	\$ -	\$ 0.56	\$ 6,828.47	Restricted	\$ 1,586,108.79	\$ 11,421,921.98
Peru Celebration Trust Account Edward Jones - Acct #6081575315	\$ 62,462.06	\$ 1,706.36	\$ -	\$ -	\$ 64,168.42	Restricted	\$ 1,586,108.79	\$ 11,486,090.40
Peru Municipal Pool Account Hometown National Bank - Acct #110741	\$ 144,356.20	\$ -	\$ -	\$ -	\$ 144,356.20	Assigned	\$ 1,586,108.79	\$ 11,630,446.60



Treasurer's Monthly Report

September 30, 2025

Fund Description
Financial Institution - Account #

SPECIAL REVENUE FUNDS

Fund Description	Previous Period Balance	Receipts	Disbursements	Interest Earned	End of Period Balance	Balance Use Definition
Insurance Fund						
LSB-HRA/SA Acct #7179	\$ 1,098,871.56	\$ 9,352.75	\$ (150,519.43)	\$ 1,870.26	\$ 959,575.14	Committed
Total Insurance Fund	\$ 959,575.14					
Garbage Fund						
Peru Federal Account #161314228	\$ 83,830.30	\$ 102,842.93	\$ (79,883.67)	\$ 262.47	\$ 107,052.03	Committed
Total Garbage Fund	\$ 107,052.03					
Motor Fuel Tax Fund						
Hometown National Bank - Acct #72660101	\$ 670,574.76	\$ 41,597.05	\$ -	\$ 1,205.32	\$ 713,377.13	Restricted
Total Motor Fuel Tax Fund	\$ 713,377.13					
Peru Police Drug Enforcement, Impound & Equipment Fund						
Peru Federal Account Acct #161317890	\$ 29,754.29	\$ -	\$ -	\$ 7.83	\$ 29,762.12	Restricted
Midland States Bank Acct #5405000027	\$ 93,352.48	\$ 2,165.25	\$ (130.69)	\$ 1.54	\$ 95,388.58	Restricted
Total Police related Special Revenue Funds	\$ 125,150.70					
TIF 2 Fund - Peru Industrial						
Heartland Acct #6506410	\$ 1,155,066.43	\$ 87,858.70	\$ -	\$ 998.38	\$ 1,243,923.51	Committed
TIF 3 Fund - North Peru						
Heartland Acct #6506410	\$ 180,487.86	\$ 65,745.87	\$ -	\$ 156.00	\$ 246,389.73	Committed
TIF 4 Fund - Downtown						
Heartland Acct #6506410	\$ 488,881.23	\$ 147,056.02	\$ -	\$ 422.56	\$ 636,359.81	Committed
TIF 5 Fund - Peru Mail						
Heartland Acct #6506410	\$ 92,875.85	\$ 25,724.89	\$ -	\$ 80.28	\$ 118,681.02	Committed
TIF 6 Fund - MVP						
Heartland Acct #6506410	\$ (444,089.11)	\$ -	\$ -	\$ -	\$ (444,089.11)	Committed
TIF 7 Fund - MINT						
Heartland Acct #6506410	\$ (58,751.65)	\$ -	\$ (3,029.64)	\$ -	\$ (61,781.29)	Committed
Total TIF Funds	\$ 1,739,483.67					
TOTAL SPECIAL REVENUE FUNDS	\$ 3,644,638.67					



Treasurer's Monthly Report

September 30, 2025

Fund Description
Financial Institution - Account #

ENTERPRISE FUNDS

Utility Fund-Electric Enterprise Fund Operating Accounts

Fund Description	Previous Period Balance	Receipts	Disbursements	Interest Earned	End of Period Balance	Balance Use Definition
Operating Checking Account	\$ 114,168.13	\$ 2,409,567.44	\$ (2,389,156.03)	\$ 639.42	\$ 135,218.96	Unassigned
Heartland - Acct #6506429						
Operating Revenue Checking Account	\$ 763,927.79	\$ 4,732,232.95	\$ (4,232,780.13)	\$ 2,391.79	\$ 1,265,772.40	Unassigned
Peru Federal Account #161314228/#162310209						
Electric Reserve	\$ -	\$ 240,000.00	\$ (21,952.29)	\$ 22,830.41	\$ 240,878.12	Assigned
DA Davidson Acct #18929160						
Guaranteed Light Deposit Checking Account	\$ 842,268.29	\$ 4,950.00	\$ (7,023.00)	\$ 2,637.07	\$ 842,832.36	Restricted
Peru Federal Account #161314228						
Operating Reserve Accounts	\$ (137,593.02)	\$ 516,952.29	\$ -	\$ -	\$ 379,359.27	Assigned
Heartland Bank - Acct #5840023088						
Operating Reserve Account	\$ (129,962.68)	\$ -	\$ (500,761.30)	\$ 16,867.18	\$ (613,856.80)	Assigned
Operating Reserve Account						
Hometown Bank-Acct #27591002589						
Substation Reserve	\$ 754,730.46	\$ -	\$ -	\$ -	\$ 754,730.46	Committed
Hometown Bank-Acct #27591002589						
N Trnk Line/Deep Sewer Reserve	\$ 2,399,250.00	\$ -	\$ -	\$ -	\$ 2,399,250.00	Restricted
Hometown Bank-Acct #27591002589						

Utility Fund-Electric Enterprise Fund Investments

Certificate of Deposit Investments for Operating Reserve	\$ 5,456,975.20	\$ -	\$ (735,000.00)	\$ -	\$ 4,721,975.20	Assigned
Certificate of Deposit Investments for Self Insurance Reserve	\$ 763,089.04	\$ -	\$ (256,544.52)	\$ -	\$ 506,544.52	Committed
Total Utility Fund-Electric Fund Operating and Investment Accounts					\$10,632,704.49	

Utility Fund-Waterworks & Sewerage System Enterprise Fund

Guaranteed Water Deposits Peru Federal Checking Account #161314228	\$ 55,141.07	\$ 450.00	\$ (820.00)	\$ 172.64	\$ 54,943.71	Restricted
Total Waterworks & Sewerage System Enterprise Fund					\$54,943.71	

Utility Fund-Enterprise Funds Bond Reserves

2021 Bond Reserve	\$ 82,861.51	\$ 11,408.33	\$ -	\$ -	\$ 94,269.84	Restricted
Heartland Bank - Acct #5840023088						
Total Utility Fund-Enterprise Debt Service Fund					\$94,269.84	

Total Utility Fund-Enterprise Funds

Operating, Investment and Debt Service Accounts					\$10,781,918.04	
--	--	--	--	--	------------------------	--



Treasurer's Monthly Report

September 30, 2025

Fund Description Financial Institution - Account #	Previous Period Balance	Receipts	Disbursements	Interest Earned	End of Period Balance	Balance Use Definition
Landfill Enterprise Fund						
Operating Checking Account	\$ 856,984.58	4,860.00	\$ (10,350.62)	\$ 2,683.15	\$ 854,177.11	Unassigned
Peru Federal Account #161314228#162310209						
Landfill No. 3 Closure/Post Closure Money Market Account	\$ 239,069.12	-	\$ -	\$ 459.63	\$ 239,528.75	Restricted
Hearland -Acct.58-4023088						
Total Landfill Enterprise Fund						
						\$1,093,705.86
Illinois Valley Regional Airport Enterprise Fund						
Peru Federal Account #161314228#162310209	\$ (580,732.64)	62,177.08	\$ (8,581.10)	\$ -	\$ (527,136.66)	Unassigned
Farm Cash Rent Account - Hertz Management - Hearland	\$ 8,479.86	-	\$ -	\$ 9.52	\$ 8,489.38	Unassigned
Total Illinois Valley Regional Airport Enterprise Fund						
						(\$518,647.28)
TOTAL ENTERPRISE FUNDS						\$11,356,976.62

FUND BALANCES

Fund Type	Amount
General Fund	\$ 11,630,446.60
Special Revenue Funds	3,644,638.67
Enterprise Funds	11,356,976.62
Total Of All Fund Types	\$ 26,632,061.89

GASB STATEMENT 54 FUND CLASSIFICATIONS

	Amount
Restricted Fund Balances	\$ 13,946,721.35
Committed Fund Balances	\$ 4,489,998.57
Assigned Fund Balances	\$ 4,872,711.99
Unassigned Fund Balances	\$ 3,322,629.98
Total of All Fund Characteristics	\$ 26,632,061.89



CONCENTRATION REPORT FOR APPROVED DEPOSITORIES AND INVESTMENTS

Financial Institution/Account(s) Description	Amount	FDIC Insurance of Accounts	Market Value Of Pledged Collateral	Deposit Risk Exposure
The Illinois Funds	\$ 8,962,198.64	N/A	N/A	\$ -
Hometown National Bank Transaction Accounts	\$ 1,486,406.89	\$ 250,000.00	\$ 3,096,591.18	\$ -
Hometown National Bank Investment Accounts	\$ 2,540,123.66	N/A	N/A	\$ -
Midland Bank Transaction Accounts	\$ 95,388.58	\$ 250,000.00	\$ -	\$ -
Peru Federal Savings Transaction Accounts	\$ 3,056,844.29	\$ 250,000.00	\$ 6,683,844.00	\$ -
Peru Federal Savings Money Market Account	\$ 824,815.47			
Heartland Transaction Accounts	\$ 2,690,684.43	\$ 250,000.00	\$ 3,346,771.07	\$ -
La Salle State Bank Transaction Accounts	\$ 959,575.14			
La Salle State Bank CD Investments	\$ 732,458.53	\$ 250,000.00	\$ 1,070,005.80	\$ -
Central Bank CD Investments	\$ 780,449.69	\$ 250,000.00	\$ 908,616.28	\$ -
Negotiable Certificates of Deposit Investments	\$ 3,941,525.51	\$ 3,941,525.51	N/A	\$ -
First State Bank CD Investments	\$ 256,544.52	\$ 250,000.00	\$ 274,405.11	\$ -
Edward Jones - Money Markets	\$ 64,168.42	\$ 250,000.00	\$ -	\$ -
DA Davidson Money Market	\$ 240,878.12	\$ 250,000.00	\$ -	\$ -
Total	\$ 26,632,061.89		Total Deposit Risk Exposure	\$ -



FIREFIGHTER'S PENSION TRUST FUND

Financial Institution	Investment Type	Previous Period Balance	Value Held at State	Receipts or Inc in Market Value	Disbursements or Loss of Market Value	End of Period Balance
Downstate Investment and Hometown National Bank-Trustee	Multiple Investments	\$125,681.38	\$3,308,825.50	\$19,389.58	\$ (21,432.08)	\$3,432,464.38

POLICE PENSION TRUST FUND

Financial Institution	Investment Type	Previous Period Balance	Value Held at State/Ins. Ann	Receipts or Inc in Market Value	Disbursements or Loss of Market Value	End of Period Balance
Downstate Investment and Hometown National Bank-Trustee	Multiple Investments	\$3,234,220.99	\$13,239,038.43	\$252,974.42	\$ (105,815.24)	\$16,620,418.60

COMBINED OPERATING ACCOUNT STATUS-PFSB

Fund Operating Checking Account Description	Operating Balance	Negative Balance
Electric Fund - Guaranteed Light Deposits	\$842,832	
Electric Fund Operating Reserve	\$1,266,772	
Garbage Fund	\$107,052	
Illinois Valley Regional Airport	(\$527,137)	(\$527,137)
Landfill Operating	\$854,177	
Motel Tax	\$422,613	
Water & Sewer - Guaranteed Water Deposits	\$54,944	
Totals	\$3,020,254	(\$527,137)
Less Electric Fund - Guaranteed Light Deposits	(\$842,832)	
Less Water & Sewer - Guaranteed Water Deposits	(\$54,944)	
Net Funds Available in Combined Operating Account	\$2,122,478	

FUND INVESTMENTS

Fund	Financial Firm	Investment Type	Account #	Balance	Rate	Maturity Date	Balance Use Definition
General Fund							
Operating Reserve	Peru Federal Savings Bank	MM	161000266	\$824,815.47	3.56%	NA	Unassigned
Operating Reserve	LaSalle State Bank	CD	4817443	\$482,458.53	3.95%	20-Dec-25	Unassigned
Total General Fund				\$1,307,274.00			
Electric Light Enterprise Fund							
Electric Light Fund - Operating Reserve	UBS Bank USA	CD	90348J5M8	\$0.00	3.45%	8-Sep-25	Assigned
Electric Light Fund - Operating Reserve	North Pointe Bank	CD	666613QP2	\$0.00	4.45%	22-Sep-25	Assigned
Electric Light Fund - Operating Reserve	Open Bank	CD	68371GEP3	\$0.00	4.30%	26-Sep-25	Assigned
Electric Light Fund - Operating Reserve	Charles Schwab Bank SSB	CD	15987UDP0	\$245,000.00	4.35%	30-Oct-25	Assigned
Electric Light Fund - Operating Reserve	BOC New York	CD	06428F6X0	\$247,000.00	4.30%	31-Oct-25	Assigned
Electric Light Fund - Operating Reserve	American Express Natl Bank	CD	02589AEB4	\$250,000.00	4.70%	3-Nov-25	Assigned
Electric Light Fund - Operating Reserve	Discover Bank	CD	254673Z33	\$250,000.00	4.95%	17-Nov-25	Assigned
Electric Light Fund - Operating Reserve	Sallie Mae Bank	CD	795451CJ0	\$150,000.00	5.00%	18-Nov-25	Assigned
Electric Light Fund - Operating Reserve	Bank OZK	CD	06418CM45	\$240,000.00	4.20%	18-Nov-25	Assigned
Electric Light Fund - Operating Reserve	Central Bank	CD	1030516172	\$780,449.69	4.20%	20-Nov-25	Assigned
Electric Light Fund - Operating Reserve	US Treasury Bill	T Bill	91282CBH3	\$245,740.51	4.22%	31-Jan-26	Assigned
Electric Light Fund - Operating Reserve	US Treasury Bill	T Bill	91282CKB6	\$601,785.00	4.63%	28-Feb-26	Assigned
Electric Light Fund - Operating Reserve	Bank of New York Mellon	CD	06405VJN0	\$240,000.00	4.25%	25-Mar-26	Assigned
Electric Light Fund - Operating Reserve	Astra Bank	CD	046308AP7	\$242,000.00	4.20%	8-May-26	Assigned
Electric Light Fund - Operating Reserve	Hingham Instn For SVGS	CD	433323NQ1	\$240,000.00	4.10%	19-May-26	Assigned
Electric Light Fund - Operating Reserve	Bank of Amer NA	CD	06051XXW7	\$240,000.00	4.25%	30-Jun-26	Assigned
Electric Light Fund - Operating Reserve	Discover Bank	CD	254673P34	\$250,000.00	3.50%	10-Aug-26	Assigned
Electric Light Fund - Operating Reserve	Morgan Stanley Bank NA	CD	61690UR51	\$250,000.00	3.60%	15-Sep-26	Assigned
Electric Light Fund - Operating Reserve	Synchrony Bank	CD	87165FS54	\$250,000.00	4.70%	4-Nov-27	Assigned
Total Operating Reserve				\$4,721,975.20			
Electric Light Fund - Self Insurance Reserve	First State Bank	CD	152473	\$0.00	4.50%	16-Aug-25	Committed
Electric Light Fund - Self Insurance Reserve	LaSalle State Bank	CD	4816390	\$250,000.00	4.30%	3-Dec-25	Committed
Electric Light Fund - Self Insurance Reserve	First State Bank	CD	152479	\$256,544.52	4.25%	16-Feb-26	Committed
Total Self Insurance Reserve				\$506,544.52			
Total Electric Light Fund Enterprise				\$5,228,519.72			
Total Fund Investments				\$6,535,793.72			

Certificate of Deposit Investments by Depos	Amount
Purchased Negotiable Certificates of Deposit	\$3,941,525.51
Central Bank Certificates of Deposit	\$780,449.69
LaSalle State Bank Certificate of Deposit	\$732,458.53
Peru Federal Savings Bank Money Market	\$824,815.47
First State Bank Certificate of Deposit	\$256,544.52
Total Certificate of Deposit Investments	\$6,535,793.72

CITY CLERK'S REPORT OF CASH RECEIVED
SEPTEMBER 2025

GENERAL FUND

Road & Bridge Property Tax	42,699.12	
Municipal Sales Tax-June Sales	711,948.46	
HRT-Parkside-June Sales	227,535.01	
HRT-Infrastructure-June Sales	227,535.00	
Use Tax	10,165.89	
Telecommunications Tax	8,398.53	
Personal Property Replacement Tax	-	
State Income Tax	88,118.71	
Other Misc Tax	21,529.40	
Video Gaming Municipal Share-June	42,073.55	
Motel Tax	100,054.63	
Health Insurance Reimbursements-Retirees	2,410.20	
Gaming Licenses	525.00	
Liquor Licenses	-	
Business/Miscellaneous Licenses	-	
Contractor Licenses	1,300.00	
Police Fines/Copies/Misc	-	
Circuit Court Fines	4,460.63	
Adjudication Fines	6,740.93	
Dimmick Fire Protctn	-	
Misc Fire Income	-	
Vacant Prop Reg	-	
AT&T Franchise-monthly	755.55	
Qtrly Cable Franchise	-	
Utility Fund Franchise-monthly	146,000.00	
Building Permits	1,412.34	
Inspection fees	750.00	
Filing Fee/Variance	200.00	
Telecomm Tower Rent	-	
BB Field Fees	-	
Park Shelter Fees	-	
Taste 50/50 Tickets	-	
Accident Damages Reimbursement	-	
Property Rent-annual Link Media	-	
Property Rent-Babs Brew	200.00	
Vital Records	1,238.00	
Recreation Receipts	-	
Cemetery Lots	2,400.00	
Burial Permits	200.00	
Cemetery Niches	-	
Donations	2,000.00	
CSO Donation to Celebration Fund	100.00	
Jr. Police Academy Reimb	494.11	
Taste of IV Liquor Refund	82.86	
HR Green Refund	97.50	
Criss Proration	297.71	
Fire Door Reimb	12,505.00	
Blue & Red Xmas Reimb	382.84	
Sale of City Property	1,083.00	
IDOT Rt 6 Mntnce	-	
State of IL-Highway Safety Grant	7,402.05	
Interest Income	38,793.33	
	38,793.33	
<i>Total General Fund</i>		<u>\$ 1,711,889.35</u>

CITY CLERK'S REPORT OF CASH RECEIVED
SEPTEMBER 2025

POLICE DRUG ENFORCE/IMPOUND/EQUIP FUND

Drug Fine/Forfeiture Income	-	
Impound Fees	2,095.25	
Other Revenue	70.00	
Interest Income	9.37	
<i>Total Police Drug/Impound Fund</i>		<u>\$ 2,174.62</u>

INSURANCE FUND

General Fund-Flexpay PR Deductions	4,085.98	
Utility Fund-HRA Reimbursements	2,890.49	
General Fund-HRA Reimbursements	2,376.28	
Utility Fund-Funding	-	
General Fund-Funding	-	
Interest Income	1,870.26	
		<u>\$ 11,223.01</u>

GARBAGE FUND

Billing Receipts	102,842.93	
Interest Income	262.47	
<i>Total Garbage Fund</i>		<u>\$ 103,105.40</u>

MOTOR FUEL TAX FUND

St of IL-MFT Allotment	20,353.68	
St of IL-Renewal Funds	21,243.37	
Interest Income	1,205.32	
<i>Total Motor Fuel Tax Fund</i>		<u>\$ 42,802.37</u>

PERU INDUSTRIAL PARK TIF

Property Taxes	87,858.70	
Interest Income	998.38	

NORTH PERU TIF

Property Taxes	65,745.87	
Interest Income	156.00	

PERU DOWNTOWN TIF

Property Taxes	147,056.02	
Interest Income	422.56	

PERU MALL TIF

Property Taxes	25,724.89	
Interest Income	80.28	

PERU MVP TIF

Property Taxes	-	
Interest Income	-	

PERU MIN TIF

Property Taxes	-	
Interest Income	-	

		<u>\$ 328,042.70</u>
--	--	----------------------

CITY CLERK'S REPORT OF CASH RECEIVED
SEPTEMBER 2025

UTILITY FUND

Billing Receipts	3,926,195.93	
Reconnect Fees	-	
NSF Fees	-	
CC Fees	7,761.41	
WC Reimbursement	-	
Fiber Optic Rent	2,809.98	
Sale of Meters/Supplies	-	
Sale of Scrap Wire	-	
Health Insurance Reimbursements-Retirees	2,329.62	
Accident Damages-Insurance Reimb	19,251.62	
Comcast-Pole Rent	-	
Sale of Loads of Water	1,354.17	
Wastewater Permits	-	
Wastewater Analysis	3,340.00	
IDOT-Traffic Signal Maint Reimb	390.53	
VJF Construction Reimbursement	-	
Interest Income	<u>57,433.33</u>	
		<u>\$ 4,020,866.59</u>

Total Electric Fund

GUARANTEED DEPOSIT FUND

Electric Utility Deposits	4,950.00	
Water Utility Deposits	<u>450.00</u>	
		<u>\$ 5,400.00</u>

Total Guaranteed Deposit Fund

LANDFILL FUND

Billing Receipts	4,860.00	
Chipper Services	-	
Interest Income	<u>3,142.78</u>	
		<u>\$ 8,002.78</u>

Total Landfill Fund

AIRPORT OPERATIONS

Hangar Rentals	7,944.09		
Land Leases	-		
Midwest Avtech-Flowage Fees	1,123.50		
Tollway Fee Reimbursement	-	\$	-
Grants	54,109.49		
Interest Income	<u>9.52</u>		
		<u>\$</u>	<u>63,186.60</u>

Total Airport Operations Fund

TOTAL ALL FUNDS

\$ 6,296,693.42

City of Peru Disbursements to be Paid 10/22/2025
--

FUND	FUND NAME		
10	General Fund	\$	767,368.05
34	TIF Funds	\$	14,824.75
60	Utility Fund	\$	2,583,181.70
85	Airport Fund	\$	3,030.07
		\$	<u>3,368,404.57</u>

VENDOR	ACCOUNT	DETAIL	AMOUNT	FUND	DEPARTMENT	ACCOUNT DESCRIPTION
IV NET	10 -5-12-56100	MONTHLY PORT-CLERK	\$ 75.00	GENERAL	CLERK'S OFFICE	TELEPHONE/INTERNET/CABLE
IL DEPT OF PUBLIC HEALT	10 -5-12-56500	DEATH CERT COPIES	\$ 664.00	GENERAL	CLERK'S OFFICE	VITAL RECORDS
QUILL CORPORATION	10 -5-12-65200	OFFICE SUPPLIES	\$ 368.97	GENERAL	CLERK'S OFFICE	OPERATING SUPPLIES
CHAMLIN & ASSOCIATES IN	10 -5-14-53450	BLDG INSPEC PLAN RVWS	\$ 3,036.00	GENERAL	CITY ENGINEER	INSPEC CONSULT/PLAN RVWS
IV NET	10 -5-14-56100	MONTHLY PORT-ENG	\$ 75.00	GENERAL	CITY ENGINEER	TELEPHONE/INTERNET/CABLE
IL DEPT OF EMPLOYMENT S	10 -5-15-45300	3RD QTR 2025 UNEMPL TAX	\$ 3,666.40	GENERAL	ADMINISTRATIVE	UNEMPLOYMENT INSURANCE
IL VALLEY REGIONAL DISP	10 -5-15-52803	NOV25 PER CAP	\$ 24,080.39	GENERAL	ADMINISTRATIVE	IVRD PER CAPITA CONTRIB
FOSTER & FOSTER INC	10 -5-15-53000	FY25 GASB 75 REPORT	\$ 3,300.00	GENERAL	ADMINISTRATIVE	AUDITING SERVICE
CHAMLIN & ASSOCIATES IN	10 -5-15-53100	MISC ENGINEERING	\$ 3,360.50	GENERAL	ADMINISTRATIVE	ENGINEERING EXPENSE
CHAMLIN & ASSOCIATES IN	10 -5-15-53100	SLOUGH BAAD GRANT	\$ 8,146.50	GENERAL	ADMINISTRATIVE	ENGINEERING EXPENSE
LASALLE PUBLISHING	10 -5-15-56200	SEP25 ADS	\$ 330.00	GENERAL	ADMINISTRATIVE	PUBLISHING/ADVERTISING
LASALLE PUBLISHING	10 -5-15-56200	VETERANS SPONSOR	\$ 625.00	GENERAL	ADMINISTRATIVE	PUBLISHING/ADVERTISING
CONNECTING POINT COMPUT	10 -5-15-65200	CMS WEB MNTE PKG RNWL	\$ 510.00	GENERAL	ADMINISTRATIVE	OPERATING SUPPLIES
MAUTINO DIST CO INC	10 -5-15-65200	WATER	\$ 33.00	GENERAL	ADMINISTRATIVE	OPERATING SUPPLIES
MCS ADVERTISING	10 -5-15-91000	ECON DEV WEBSITE OCT25	\$ 1,000.00	GENERAL	ADMINISTRATIVE	ECONOMIC DEVELOPMENT
LETTERKRAFT PRINTERS	10 -5-15-94000	IV FOOD PANTRY INSERTS	\$ 853.65	GENERAL	ADMINISTRATIVE	DONATIONS
LIGHTED WAY	10 -5-15-94000	TRIVIA NIGHT DONATION	\$ 100.00	GENERAL	ADMINISTRATIVE	DONATIONS
PERU PUBLIC LIBRARY	10 -5-15-97020	PPRT RCVD 10/2/25	\$ 7,794.46	GENERAL	ADMINISTRATIVE	CONTRIB TO LIBR-PPRT
BLAKE FRUND	10 -5-16-47100	FRUND CA	\$ 74.55	GENERAL	POLICE	CLOTHING ALLOWANCE
AMAZON CAPITAL SERVICES	10 -5-16-47100	QUERCIAGROSSA CA	\$ 200.00	GENERAL	POLICE	CLOTHING ALLOWANCE
DEPUE POLICE DEPARTMENT	10 -5-16-47110	VEST PURCHASE-WINFERT	\$ 692.50	GENERAL	POLICE	OTHER UNIFORM
CHAPMAN'S MECHANICAL	10 -5-16-51100	POLC FURNACE SVC	\$ 1,940.00	GENERAL	POLICE	R&M/BUILDINGS
CONNOR CO	10 -5-16-51100	2 FLUSH VALVES	\$ 284.94	GENERAL	POLICE	R&M/BUILDINGS
KENDRICK PEST CONTROL I	10 -5-16-51100	POLICE COMPLEX	\$ 65.00	GENERAL	POLICE	R&M/BUILDINGS
KUSTOM SIGNALS INC	10 -5-16-51200	WIRED REMOTE	\$ 365.00	GENERAL	POLICE	R&M/EQUIPMENT
POMP'S TIRE SERVICE	10 -5-16-51300	PPD32 TIRES	\$ 523.00	GENERAL	POLICE	R&M/VEHICLES
SCHIMMER INC	10 -4-00-56-3650	SCHIMMER TRADE-INS SERVICE CR	\$ (8,700.00)	GENERAL	POLICE	SALE OF CITY PROPERTY
SCHIMMER INC	10 -5-16-51300	PPD23 MNTNCE	\$ 1,830.28	GENERAL	POLICE	R&M/VEHICLES
SCHIMMER INC	10 -5-16-51300	PPD44 MNTNCE	\$ 725.44	GENERAL	POLICE	R&M/VEHICLES
SCHIMMER INC	10 -5-16-51300	PPD17 MNTNCE	\$ 800.00	GENERAL	POLICE	R&M/VEHICLES
SCHIMMER INC	10 -5-16-51300	PPD44 MNTNCE	\$ 271.24	GENERAL	POLICE	R&M/VEHICLES
SCHIMMER INC	10 -5-16-51300	PPD39 MNTNCE	\$ 89.99	GENERAL	POLICE	R&M/VEHICLES
SCHIMMER INC	10 -5-16-51300	PPD38 MNTNCE	\$ 1,433.27	GENERAL	POLICE	R&M/VEHICLES
SCHIMMER INC	10 -5-16-51300	PPD46 MNTNCE	\$ 89.99	GENERAL	POLICE	R&M/VEHICLES
SCHIMMER INC	10 -5-16-51300	PPD25 MNTNCE	\$ 89.99	GENERAL	POLICE	R&M/VEHICLES
SCHIMMER INC	10 -5-16-51300	PPD42 MNTNCE	\$ 89.99	GENERAL	POLICE	R&M/VEHICLES
SCHIMMER INC	10 -5-16-51300	PPD47 MNTNCE	\$ 905.46	GENERAL	POLICE	R&M/VEHICLES

VENDOR	ACCOUNT	DETAIL	AMOUNT	FUND	DEPARTMENT	ACCOUNT DESCRIPTION
SCHIMMER INC	10 -5-16-51300	PPD32 MNTNCE	\$ 374.51	GENERAL	POLICE	R&M/VEHICLES
SCHIMMER INC	10 -5-16-51300	PPD42 MNTNCE	\$ 2,960.67	GENERAL	POLICE	R&M/VEHICLES
SCHIMMER INC	10 -5-16-51300	PPD41 MNTNCE	\$ 340.11	GENERAL	POLICE	R&M/VEHICLES
SCHIMMER INC	10 -5-16-51300	PPD37 MNTNCE	\$ 89.99	GENERAL	POLICE	R&M/VEHICLES
PRESCOTT BROS INC	10 -5-16-51300	PPD35 MNTNCE	\$ 160.05	GENERAL	POLICE	R&M/VEHICLES
PRESCOTT BROS INC	10 -5-16-51300	PPD34 MNTNCE	\$ 2,246.90	GENERAL	POLICE	R&M/VEHICLES
CASSIDY TIRE PERU, LLC	10 -5-16-51300	PPD10 TIRES	\$ 938.95	GENERAL	POLICE	R&M/VEHICLES
OSF MEDICAL GROUP-OCCUP	10 -5-16-53420	MED SVCS-SMALL	\$ 216.00	GENERAL	POLICE	MEDICAL SERVICES
OSF HEALTHCARE SYSTEM	10 -5-16-55500	CPR RNWL COURSE	\$ 113.00	GENERAL	POLICE	MEETINGS/EDUC & SAFETY EXP
IV NET	10 -5-16-56100	MONTHLY PORT-POLICE	\$ 75.00	GENERAL	POLICE	TELEPHONE/INTERNET/CABLE
PEERLESS NETWORK	10 -5-16-56100	65546-2650 PEORIA ST	\$ 206.05	GENERAL	POLICE	TELEPHONE/INTERNET/CABLE
COMCAST BUSINESS	10 -5-16-56100	POLC INTERNET TO 10/15	\$ 718.00	GENERAL	POLICE	TELEPHONE/INTERNET/CABLE
COMCAST BUSINESS	10 -5-16-56100	POLC PHONE TO 10/15	\$ 420.58	GENERAL	POLICE	TELEPHONE/INTERNET/CABLE
MARCO TECHNOLOGIES LLC	10 -5-16-56400	POLC MAINT 10/25	\$ 1,302.92	GENERAL	POLICE	MAINTENANCE AGREEMENTS
AMEREN ILLINOIS	10 -5-16-57100	13260-71020 2650 N PEORIA ST	\$ 154.51	GENERAL	POLICE	UTILITIES
PORTER LEE CORPORATION	10 -5-16-59900	BEAST SFTW SUPP	\$ 920.00	GENERAL	POLICE	CONTRACTUAL SERVICE
STERICYCLE, INC.	10 -5-16-59900	NEEDLE DISPOSAL	\$ 148.76	GENERAL	POLICE	CONTRACTUAL SERVICE
BATTERIES & THINGS	10 -5-16-65200	BATTERIES	\$ 512.00	GENERAL	POLICE	OPERATING SUPPLIES
BATTERIES & THINGS	10 -5-16-65200	BATTERIES	\$ 148.00	GENERAL	POLICE	OPERATING SUPPLIES
TRI-STATE FIRE CONTROL	10 -5-16-65200	POLC EXTGSHR MNTC	\$ 3,003.00	GENERAL	POLICE	OPERATING SUPPLIES
KIESLER POLICE SUPPLY	10 -5-16-65200	AMMO	\$ 626.44	GENERAL	POLICE	OPERATING SUPPLIES
AMAZON CAPITAL SERVICES	10 -5-16-65200	GATES/BATTERIES	\$ 588.30	GENERAL	POLICE	OPERATING SUPPLIES
CUSTOM LANYARD	10 -5-16-65200	LANYARDS	\$ 145.35	GENERAL	POLICE	OPERATING SUPPLIES
CHESSIE LANE ANIMAL HOS	10 -5-16-65220	CANINE EXAM-HAVEN	\$ 317.45	GENERAL	POLICE	SPECIAL PROGRAMS EXPENSE
TRANSUNION RISK AND ALT	10 -5-16-68400	TLO	\$ 75.00	GENERAL	POLICE	COMPUTER SOFTWARE
CHAPMAN'S MECHANICAL	10 -5-17-51100	FIRE BACKFLOW RPLC	\$ 6,701.00	GENERAL	FIRE	R&M/BUILDINGS
PERU AUTO ELECTRIC	10 -5-17-51300	316 BATTERY	\$ 597.00	GENERAL	FIRE	R&M/VEHICLES
FIRE SERVICE INC.	10 -5-17-51300	317 MNTNCE	\$ 647.38	GENERAL	FIRE	R&M/VEHICLES
OSF MEDICAL GROUP-OCCUP	10 -5-17-53420	MED SVCS-FIRE	\$ 60.00	GENERAL	FIRE	MEDICAL SERVICES
PEERLESS NETWORK	10 -5-17-56100	1128974-816 W ST	\$ 74.89	GENERAL	FIRE	TELEPHONE/INTERNET/CABLE
AMEREN ILLINOIS	10 -5-17-57100	95733-05296 1503 4TH FIRE	\$ 78.42	GENERAL	FIRE	UTILITIES
CINTAS CORP #396	10 -5-17-59900	CITY HALL/FIRE MATS	\$ 40.66	GENERAL	FIRE	CONTRACTUAL SERVICE
CINTAS CORP #396	10 -5-17-59900	FIRE MATS/SUPPL	\$ 40.66	GENERAL	FIRE	CONTRACTUAL SERVICE
CINTAS CORPORATION	10 -5-17-59900	FIRE-EYEWASH STN	\$ 75.00	GENERAL	FIRE	CONTRACTUAL SERVICE
EMERGENCY SERVICES MARK	10 -5-17-59900	RESPONSE SOFTWARE	\$ 809.10	GENERAL	FIRE	CONTRACTUAL SERVICE
HINCKLEY SPRINGS	10 -5-17-65200	FIRE-WATER SVC	\$ 116.42	GENERAL	FIRE	OPERATING SUPPLIES
DINGES FIRE COMPANY	10 -5-17-65200	DUNCAN UNIFORM	\$ 99.95	GENERAL	FIRE	OPERATING SUPPLIES

VENDOR	ACCOUNT	DETAIL	AMOUNT	FUND	DEPARTMENT	ACCOUNT DESCRIPTION
LOCKER ROOM	10 -5-17-65200	FRANK EMBROIDERY	\$ 102.00	GENERAL	FIRE	OPERATING SUPPLIES
AIR ONE EQUIP INC	10 -5-17-66520	HELMETS	\$ 419.00	GENERAL	FIRE	TURNOUT/SAFETY GEAR
DINGES FIRE COMPANY	10 -5-17-66520	FIRE GLOVES	\$ 231.97	GENERAL	FIRE	TURNOUT/SAFETY GEAR
CHAPMAN'S MECHANICAL	10 -5-19-51100	PW AC SERVICE	\$ 578.60	GENERAL	STREET	R&M/BUILDINGS
MARTIN EQUIPMENT OF IL	10 -5-19-51200	PARTS	\$ 210.70	GENERAL	STREET	R&M/EQUIPMENT
MARTIN EQUIPMENT OF IL	10 -5-19-51200	PART	\$ 29.77	GENERAL	STREET	R&M/EQUIPMENT
SMITH'S SALES & SERVICE	10 -5-19-51200	CHAINS	\$ 190.00	GENERAL	STREET	R&M/EQUIPMENT
SMITH'S SALES & SERVICE	10 -5-19-51200	CHAINS	\$ 552.00	GENERAL	STREET	R&M/EQUIPMENT
SMITH'S SALES & SERVICE	10 -5-19-51200	PARTS	\$ 10.00	GENERAL	STREET	R&M/EQUIPMENT
JACK'S GAS & SERV INC	10 -5-19-51300	TRUCK INSPECTIONS	\$ 87.00	GENERAL	STREET	R&M/VEHICLES
JACK'S GAS & SERV INC	10 -5-19-51300	TRUCK INSPECTIONS	\$ 116.00	GENERAL	STREET	R&M/VEHICLES
JACK'S GAS & SERV INC	10 -5-19-51300	TRUCK INSPECTIONS	\$ 174.00	GENERAL	STREET	R&M/VEHICLES
JACK'S GAS & SERV INC	10 -5-19-51300	TRUCK INSPECTIONS	\$ 290.00	GENERAL	STREET	R&M/VEHICLES
NAPA AUTO PARTS	10 -5-19-51300	R401 VENT VALVE	\$ 49.31	GENERAL	STREET	R&M/VEHICLES
MIDWEST WHEEL COMPANIES	10 -5-19-51300	PRESTO PATCH	\$ 47.35	GENERAL	STREET	R&M/VEHICLES
MIDWEST WHEEL COMPANIES	10 -5-19-51300	PARTS	\$ 133.33	GENERAL	STREET	R&M/VEHICLES
MIDWEST WHEEL COMPANIES	10 -5-19-51300	BREAKER BOX	\$ 70.77	GENERAL	STREET	R&M/VEHICLES
ADVANCED ASPHALT CO	10 -5-19-51400	SURFACE MIX	\$ 617.25	GENERAL	STREET	R&M/STREETS
ADVANCED ASPHALT CO	10 -5-19-51400	SURFACE MIX	\$ 214.50	GENERAL	STREET	R&M/STREETS
MERTEL GRAVEL CO	10 -5-19-51400	GRAVEL	\$ 113.12	GENERAL	STREET	R&M/STREETS
MERTEL GRAVEL CO	10 -5-19-51400	CONCRET BLOCK VETS PK	\$ 420.00	GENERAL	STREET	R&M/STREETS
UNIVERSAL ASPHALT & EXC	10 -5-19-51434	2025 ST PRGRM PAY1	\$ 293,919.30	GENERAL	STREET	STREET MAINT PROJECT
CHAMLIN & ASSOCIATES IN	10 -5-19-51450	PLANK RD WIDENING	\$ 27,709.00	GENERAL	STREET	PLANK RD PROJ GRNT CNSTR
CHAMLIN & ASSOCIATES IN	10 -5-19-51450	PLANK RD RECONSTRUCT PH2	\$ 540.00	GENERAL	STREET	PLANK RD PROJ GRNT CNSTR
PEERLESS NETWORK	10 -5-19-56100	1128977-1012 PEORIA ST	\$ 70.95	GENERAL	STREET	TELEPHONE/INTERNET/CABLE
AMEREN ILLINOIS	10 -5-19-57100	15285-27851 RT 251	\$ 69.14	GENERAL	STREET	UTILITIES
AMEREN ILLINOIS	10 -5-19-57100	35940-87050 4003 PLNK RD	\$ 89.83	GENERAL	STREET	UTILITIES
KENDRICK PEST CONTROL I	10 -5-19-59900	8TH & GREEN	\$ 20.00	GENERAL	STREET	CONTRACTUAL SERVICE
CINTAS CORPORATION	10 -5-19-59900	PW-EYEWASH STN	\$ 150.00	GENERAL	STREET	CONTRACTUAL SERVICE
MICHAEL TODD INDUSTRIAL	10 -5-19-61200	TRIPOD STND FOR SIGNS	\$ 644.58	GENERAL	STREET	SIGNS
MICHAEL TODD INDUSTRIAL	10 -5-19-61200	SIGNS	\$ 589.12	GENERAL	STREET	SIGNS
MICHAEL TODD INDUSTRIAL	10 -5-19-61200	SIGNS	\$ 2,244.28	GENERAL	STREET	SIGNS
AIRGAS USA, LLC-NORTH D	10 -5-19-65200	OXYGEN	\$ 55.29	GENERAL	STREET	OPERATING SUPPLIES
AIRGAS USA, LLC-NORTH D	10 -5-19-65200	SAFETY GLASSES 12 PAIR	\$ 90.72	GENERAL	STREET	OPERATING SUPPLIES
JOHN DEERE FINANCIAL	10 -5-19-65200	SAFETY SUPPLIES	\$ 165.00	GENERAL	STREET	OPERATING SUPPLIES
S J SMITH CO., INC	10 -5-19-65200	ARGON MIX	\$ 6.30	GENERAL	STREET	OPERATING SUPPLIES
MATCO TOOLS	10 -5-19-65200	TOOL REPAIR	\$ 114.28	GENERAL	STREET	OPERATING SUPPLIES

VENDOR	ACCOUNT	DETAIL	AMOUNT	FUND	DEPARTMENT	ACCOUNT DESCRIPTION
ILLINOIS TOLLWAY	10 -5-19-65200	M242948 MISSED TOLLS	\$ 27.20	GENERAL	STREET	OPERATING SUPPLIES
AMAZON CAPITAL SERVICES	10 -5-19-65200	SNACKS	\$ 127.97	GENERAL	STREET	OPERATING SUPPLIES
AMAZON CAPITAL SERVICES	10 -5-19-65200	AIR FRESHENERS	\$ 11.88	GENERAL	STREET	OPERATING SUPPLIES
AMAZON CAPITAL SERVICES	10 -5-19-65200	TISSUE/COFFEE	\$ 197.49	GENERAL	STREET	OPERATING SUPPLIES
ARNESON OIL COMPANY	10 -5-19-65500	DIESEL FUEL	\$ 972.41	GENERAL	STREET	FUEL & OIL VEHICLES
ARNESON OIL COMPANY	10 -5-19-65500	DIESEL FUEL	\$ 955.06	GENERAL	STREET	FUEL & OIL VEHICLES
DEERE CREDIT INC	10 -5-19-72370	030-0074839-000/PAY 47	\$ 58.12	GENERAL	STREET	INT-JOHN DEERE CREDIT
DEERE CREDIT INC	10 -5-19-88400	030-0074839-000/PAY 47	\$ 2,039.34	GENERAL	STREET	NEW EQUIPMENT/VEHICLES
CHAPMAN'S MECHANICAL	10 -5-22-51100	FURNACE SVC	\$ 933.50	GENERAL	BUILDINGS & GROUNDS	R&M/BUILDINGS/STRUCTURES
KENDRICK PEST CONTROL I	10 -5-22-51100	MUN BLDG	\$ 40.00	GENERAL	BUILDINGS & GROUNDS	R&M/BUILDINGS/STRUCTURES
KENDRICK PEST CONTROL I	10 -5-22-51100	FIRE	\$ 40.00	GENERAL	BUILDINGS & GROUNDS	R&M/BUILDINGS/STRUCTURES
KENDRICK PEST CONTROL I	10 -5-22-51100	CEMETERY	\$ 35.00	GENERAL	BUILDINGS & GROUNDS	R&M/BUILDINGS/STRUCTURES
KENDRICK PEST CONTROL I	10 -5-22-51100	PW BLDG	\$ 35.00	GENERAL	BUILDINGS & GROUNDS	R&M/BUILDINGS/STRUCTURES
ATOR INC.	10 -5-22-51700	TOPSOIL WASH PARK	\$ 720.00	GENERAL	BUILDINGS & GROUNDS	R&M/GROUNDS
IL VALLEY EXCAVATING IN	10 -5-22-51700	EMRGNCY RESPONSE 251 BRIDGE	\$ 10,592.00	GENERAL	BUILDINGS & GROUNDS	R&M/GROUNDS
COUNTRY KIDS FARM FRESH	10 -5-22-51700	FALL DISPLAY	\$ 1,475.00	GENERAL	BUILDINGS & GROUNDS	R&M/GROUNDS
TAYLOR'S WAY	10 -5-22-51700	TREE FERTILIZATION	\$ 179.00	GENERAL	BUILDINGS & GROUNDS	R&M/GROUNDS
PEERLESS NETWORK	10 -5-22-56100	1128988-1901 4TH ST-ADM	\$ 426.14	GENERAL	BUILDINGS & GROUNDS	TELEPHONE
AMEREN ILLINOIS	10 -5-22-57100	BOAT LAUNCH LTS	\$ 23.46	GENERAL	BUILDINGS & GROUNDS	UTILITIES
AMEREN ILLINOIS	10 -5-22-57100	77250-21000 1901 4TH	\$ 88.31	GENERAL	BUILDINGS & GROUNDS	UTILITIES
CINTAS CORP #396	10 -5-22-59900	CITY HALL/FIRE MATS	\$ 93.74	GENERAL	BUILDINGS & GROUNDS	CONTRACTUAL SERVICE
SERVICEMASTER BEST CLEA	10 -5-22-59900	PW SEP25 CLEAN	\$ 650.00	GENERAL	BUILDINGS & GROUNDS	CONTRACTUAL SERVICE
ILLINOIS MILITARY MAINT	10 -5-22-59900	CLEAN 9/6-9/27	\$ 800.00	GENERAL	BUILDINGS & GROUNDS	CONTRACTUAL SERVICE
LASALLE CO TREASURER	10 -5-22-91790	11-77-432-001/LSHLD DIMMICK SU	\$ 685.24	GENERAL	BUILDINGS & GROUNDS	PROPERTY TAX
AMAZON CAPITAL SERVICES	10 -5-23-47100	GHIGHI UNIF	\$ 478.75	GENERAL	PARKS	CLOTHING ALLOWANCE
SMITH'S SALES & SERVICE	10 -5-23-51200	EQUIP MNTNCE	\$ 1,622.00	GENERAL	PARKS	R&M/EQUIPMENT
SMITH'S SALES & SERVICE	10 -5-23-51200	CAP	\$ 37.00	GENERAL	PARKS	R&M/EQUIPMENT
SMITH'S SALES & SERVICE	10 -5-23-51200	BLADES/BOLT	\$ 163.00	GENERAL	PARKS	R&M/EQUIPMENT
SMITH'S SALES & SERVICE	10 -5-23-51200	MOWER MNTNCE	\$ 683.00	GENERAL	PARKS	R&M/EQUIPMENT
TURFWERKS	10 -5-23-51200	ABI PART	\$ 599.00	GENERAL	PARKS	R&M/EQUIPMENT
AMEREN ILLINOIS	10 -5-23-57100	29031-01038 1301 PARK RD	\$ 65.16	GENERAL	PARKS	UTILITIES
CINTAS CORPORATION	10 -5-23-59900	REC GRG EYEWASH STN	\$ 75.00	GENERAL	PARKS	CONTRACTUAL SERVICE
MAZE LUMBER COMPANY	10 -5-23-65200	QUIKRETE	\$ 110.00	GENERAL	PARKS	OPERATING SUPPLIES
MAZE LUMBER COMPANY	10 -5-23-65200	QUIKRETE	\$ 22.00	GENERAL	PARKS	OPERATING SUPPLIES
JOHN DEERE FINANCIAL	10 -5-23-65200	SUPPLIES	\$ 391.87	GENERAL	PARKS	OPERATING SUPPLIES
LADD FARM MART	10 -5-23-65200	ROLLER ASSY	\$ 15.59	GENERAL	PARKS	OPERATING SUPPLIES
LADD SOUND PRODUCTIONS	10 -5-23-65210	STAGE RISER	\$ 100.00	GENERAL	PARKS	EVENTS/PROGRAMS

VENDOR	ACCOUNT	DETAIL	AMOUNT	FUND	DEPARTMENT	ACCOUNT DESCRIPTION
MARK CIHLAR	10 -5-23-65210	MUSIC IN THE PARK	\$ 175.00	GENERAL	PARKS	EVENTS/PROGRAMS
THADDEUS KROLICKI	10 -5-23-65210	MUSIC IN THE PARK	\$ 175.00	GENERAL	PARKS	EVENTS/PROGRAMS
WILLIE BUCK	10 -5-23-65210	MUSIC IN THE PARK	\$ 250.00	GENERAL	PARKS	EVENTS/PROGRAMS
PAUL & SANDY GARRET	10 -5-23-65210	MUSIC IN THE PARK	\$ 150.00	GENERAL	PARKS	EVENTS/PROGRAMS
MERTEL GRAVEL CO	10 -5-23-65211	AIR SHOW BLOCKS	\$ 825.00	GENERAL	PARKS	TBM AVENGER EVENT
FIRST WESTERN EQUIPMENT	10 -5-23-72370	LEASE/PURCH	\$ 57.56	GENERAL	PARKS	LEASE FEES/INTEREST
NEW EQUIPMENT LEASING I	10 -5-23-72370	2023 EXMARK MOWER-PAY 31	\$ 12.63	GENERAL	PARKS	LEASE FEES/INTEREST
FIRST WESTERN EQUIPMENT	10 -5-23-88000	LEASE/PURCH	\$ 492.61	GENERAL	PARKS	NEW EQUIPMENT
NEW EQUIPMENT LEASING I	10 -5-23-88000	2023 EXMARK MOWER-PAY 31	\$ 2,148.37	GENERAL	PARKS	NEW EQUIPMENT
CHAMLIN & ASSOCIATES IN	10 -5-23-89500	OSLAD ENGINEERING	\$ 1,070.00	GENERAL	PARKS	CONSTRUCTION
SKI SEALCOATING & MAINT	10 -5-23-89500	WASH PRK OSLAD PAY2	\$ 34,226.15	GENERAL	PARKS	CONSTRUCTION
MERTEL GRAVEL CO	10 -5-24-51100	CMTRY CONCRETE BLOCKS	\$ 420.00	GENERAL	CEMETERY	R&M/BUILDINGS
MERTEL GRAVEL CO	10 -5-24-51100	CMTRY CONCRETE	\$ 384.00	GENERAL	CEMETERY	R&M/BUILDINGS
PEERLESS NETWORK	10 -5-24-56100	1128981-2121 SHOOTING PARK RD	\$ 83.09	GENERAL	CEMETERY	TELEPHONE/INTERNET/CABLE
AMEREN ILLINOIS	10 -5-24-57100	56462-08657 SHOOTING PK RD	\$ 70.19	GENERAL	CEMETERY	UTILITIES
AMEREN ILLINOIS	10 -5-24-57100	87671-76497 MAUSOLEUM	\$ 65.16	GENERAL	CEMETERY	UTILITIES
CINTAS CORPORATION	10 -5-24-59900	CMTRY EYEWASH STN	\$ 130.00	GENERAL	CEMETERY	CONTRACTUAL SERVICE
THE ECONOMIC DEV GROUP,	31 -5-90-53400	DWNTWN TIF4 3RD QTR FEES	\$ 6,372.00	DOWNTOWN TIF	OPERATING EXPENSES	LEGAL/PROF FEES
JACOB & KLEIN, LTD	31 -5-90-53400	DWNTWN TIF4 2ND QTR FEES	\$ 1,593.00	DOWNTOWN TIF	OPERATING EXPENSES	LEGAL/PROF FEES
THE ECONOMIC DEV GROUP,	32 -5-90-53400	MALL TIF5 1ST QTR FEES	\$ 1,211.60	PERU MALL TIF	OPERATING EXPENSES	LEGAL/PROF FEES
JACOB & KLEIN, LTD	32 -5-90-53400	MALL TIF5 3RD QTR FEES	\$ 302.90	PERU MALL TIF	OPERATING EXPENSES	LEGAL/PROF FEES
THE ECONOMIC DEV GROUP,	33 -5-90-53400	MVP TIF6 3RD QTR FEES	\$ 4,276.20	MVP TIF	OPERATING EXPENSES	LEGAL/PROF FEES
JACOB & KLEIN, LTD	33 -5-90-53400	MVP TIF6 3RD QTR FEES	\$ 1,069.05	MVP TIF	OPERATING EXPENSES	LEGAL/PROF FEES
IL DEPT OF REVENUE	60 -20600	SEP25 UTILITY TAX	\$ 73,139.40	UTILITY	NA	UTILITY TAX
IL EPA	60 -20910	WWTR-4&6 LOAN #24	\$ 115,164.05	UTILITY	DEBT	FED/IEPA STIMULUS LOAN
LETTERKRAFT PRINTERS	60 -5-12-56000	FINAL NOTICE POSTCARDS	\$ 767.38	UTILITY	CLERK'S OFFICE	POSTAGE
CREATIVE SERVICES	60 -5-12-56000	SEP25 UTIL BILLS	\$ 3,214.58	UTILITY	CLERK'S OFFICE	POSTAGE
CREATIVE SERVICES	60 -5-12-59900	SEP25 UTIL BILLS	\$ 580.46	UTILITY	CLERK'S OFFICE	CONTRACTUAL SERVICE
LETTERKRAFT PRINTERS	60 -5-12-65200	FINAL NOTICE POSTCARDS	\$ 239.02	UTILITY	CLERK'S OFFICE	OPERATING SUPPLIES
JOHN DEERE FINANCIAL	60 -5-15-47100	URBANC CA	\$ 54.99	UTILITY	ADMINISTRATIVE	CLOTHING ALLOWANCE
SLATE ROCK FR	60 -5-15-47100	FRANK CA	\$ 247.56	UTILITY	ADMINISTRATIVE	CLOTHING ALLOWANCE
SLATE ROCK FR	60 -5-15-47200	LYNCH UNIF	\$ 279.24	UTILITY	ADMINISTRATIVE	UNIFORM SERVICE
BHMG ENGINEERS	60 -5-15-53100	EPA & ANN RPT	\$ 1,200.96	UTILITY	ADMINISTRATIVE	ENGINEERING EXPENSE
GREATER MIDWEST APPRAIS	60 -5-15-53200	HALM SUBDVSN TO AMEREN	\$ 2,500.00	UTILITY	ADMINISTRATIVE	LEGAL FEES
PAYMENTECH	60 -5-15-53500	AUG25 CC FEES	\$ 972.16	UTILITY	ADMINISTRATIVE	BANK FEES/SERVICE CHARGES
PAYMENTECH	60 -5-15-53500	AUG25 WEB FEES	\$ 3,330.84	UTILITY	ADMINISTRATIVE	BANK FEES/SERVICE CHARGES
IMUA-IL MUNICIPAL UTILI	60 -5-15-55500	TVPPA LINEMAN CLASSES-CUMMINGS	\$ 1,506.50	UTILITY	ADMINISTRATIVE	EDUCATION/MEETINGS

VENDOR	ACCOUNT	DETAIL	AMOUNT	FUND	DEPARTMENT	ACCOUNT DESCRIPTION
TENNESSEE VALLEY PUBLIC	60 -5-15-55500	SHEVLIN-TRNG	\$ 898.50	UTILITY	ADMINISTRATIVE	EDUCATION/MEETINGS
KEVIN MINNICK	60 -5-15-55500	IMEA MTG REIMB	\$ 12.52	UTILITY	ADMINISTRATIVE	EDUCATION/MEETINGS
ZACHARY FRANK	60 -5-15-55900	TRAINING REIMB	\$ 738.83	UTILITY	ADMINISTRATIVE	TRAVEL/MILEAGE
IV NET	60 -5-15-56100	OCT25 PORT CHARGES	\$ 150.00	UTILITY	ADMINISTRATIVE	TELEPHONE/INTERNET/CABLE
PEERLESS NETWORK	60 -5-15-56100	1128979 4005 PLANK RD	\$ 83.09	UTILITY	ADMINISTRATIVE	TELEPHONE/INTERNET/CABLE
CINTAS CORP #396	60 -5-15-59900	ELEC MATS/SUPPL CR	\$ (132.00)	UTILITY	ADMINISTRATIVE	CONTRACTUAL SERVICES
CINTAS CORP #396	60 -5-15-59900	ELEC MATS/SUPPL	\$ 235.38	UTILITY	ADMINISTRATIVE	CONTRACTUAL SERVICES
CINTAS CORP #396	60 -5-15-59900	ELEC MATS/SUPPL	\$ 61.20	UTILITY	ADMINISTRATIVE	CONTRACTUAL SERVICES
CINTAS CORP #396	60 -5-15-59900	ELEC MATS/SUPPL	\$ 209.89	UTILITY	ADMINISTRATIVE	CONTRACTUAL SERVICES
CINTAS CORP #396	60 -5-15-59900	PW MATS/SUPPL	\$ 283.91	UTILITY	ADMINISTRATIVE	CONTRACTUAL SERVICES
CINTAS CORP #396	60 -5-15-59900	ELEC MATS/SUPPL	\$ 61.20	UTILITY	ADMINISTRATIVE	CONTRACTUAL SERVICES
CINTAS CORP #396	60 -5-15-59900	PW MATS/SUPPL	\$ 96.60	UTILITY	ADMINISTRATIVE	CONTRACTUAL SERVICES
CINTAS CORP #396	60 -5-15-59900	ELEC MATS/SUPPL	\$ 61.20	UTILITY	ADMINISTRATIVE	CONTRACTUAL SERVICES
CINTAS CORPORATION	60 -5-15-59900	ELEC-EYEWASH STN	\$ 198.36	UTILITY	ADMINISTRATIVE	CONTRACTUAL SERVICES
SERVICEMASTER BEST CLEA	60 -5-15-59900	ELEC SEP25 CLEAN	\$ 975.00	UTILITY	ADMINISTRATIVE	CONTRACTUAL SERVICES
THE HOME CITY ICE COMPA	60 -5-15-65200	ICE	\$ 301.20	UTILITY	ADMINISTRATIVE	OPERATING SUPPLIES
BRENT MARTIN	60 -5-15-92900	DEPT LUNCH	\$ 74.66	UTILITY	ADMINISTRATIVE	MISCELLANEOUS
IL EPA	60 -5-15-93000	AIR POLLUTION TITLE V PERMIT	\$ 5,959.00	UTILITY	ADMINISTRATIVE	LICENSE/PERMITS
KENDRICK PEST CONTROL I	60 -5-61-51100	PLANT & BLDGS	\$ 15.00	UTILITY	POWER & GENERATION	R&M/BUILDINGS
KENDRICK PEST CONTROL I	60 -5-61-51100	HYDRO	\$ 15.00	UTILITY	POWER & GENERATION	R&M/BUILDINGS
T & T HYDRAULICS	60 -5-61-51200	PARTS	\$ 134.12	UTILITY	POWER & GENERATION	R&M/EQUIPMENT
STUART C IRBY CO	60 -5-61-51200	EQUIP TESTING	\$ 1,924.00	UTILITY	POWER & GENERATION	R&M/EQUIPMENT
BHMG ENGINEERS	60 -5-61-53100	COORDNTN STUDY	\$ 16,103.73	UTILITY	POWER & GENERATION	ENGINEERING EXPENSE
POWER MONITORS, INC	60 -5-61-59900	PQ SFTWRE-2/2026	\$ 365.00	UTILITY	POWER & GENERATION	CONTRACTUAL SERVICES
IL MUNICIPAL ELECTRIC A	60 -5-61-64310	SEP 2025 LARGE POWER	\$ 1,599,313.73	UTILITY	POWER & GENERATION	LARGE POWER PURCHASE
AMEREN ILLINOIS	60 -5-61-66720	66792-35002 1026 CENTER ST	\$ 65.16	UTILITY	POWER & GENERATION	UTILITIES
AMEREN ILLINOIS	60 -5-61-66720	69001-44002 4003 PLNK RD	\$ 65.16	UTILITY	POWER & GENERATION	UTILITIES
MARTIN EQUIPMENT OF IL	60 -5-62-51200	RPLC BROKEN COUPLER	\$ 199.70	UTILITY	DISTRIBUTION SYSTEM	R&M/EQUIPMENT
MARTIN EQUIPMENT OF IL	60 -5-62-51200	EQUIP MNTNCE	\$ 51.76	UTILITY	DISTRIBUTION SYSTEM	R&M/EQUIPMENT
ON SITE REPAIR SERVICES	60 -5-62-51200	EQUIP MNTNCE	\$ 301.79	UTILITY	DISTRIBUTION SYSTEM	R&M/EQUIPMENT
SMITH'S SALES & SERVICE	60 -5-62-51200	CHAINS	\$ 90.00	UTILITY	DISTRIBUTION SYSTEM	R&M/EQUIPMENT
MERTEL GRAVEL CO	60 -5-62-51290	CONCRETE	\$ 636.00	UTILITY	DISTRIBUTION SYSTEM	R&M/DIST EQUIP/LINES/SVCS
MERTEL GRAVEL CO	60 -5-62-51290	CONCRETE	\$ 526.00	UTILITY	DISTRIBUTION SYSTEM	R&M/DIST EQUIP/LINES/SVCS
MERTEL GRAVEL CO	60 -5-62-51290	CONCRETE SPLASH PAD	\$ 565.50	UTILITY	DISTRIBUTION SYSTEM	R&M/DIST EQUIP/LINES/SVCS
ECHO ELECTRIC	60 -5-62-51290	DISTR SUPPLIES	\$ 2.48	UTILITY	DISTRIBUTION SYSTEM	R&M/DIST EQUIP/LINES/SVCS
ECHO ELECTRIC	60 -5-62-51290	WIRE	\$ 3,589.81	UTILITY	DISTRIBUTION SYSTEM	R&M/DIST EQUIP/LINES/SVCS
ECHO ELECTRIC	60 -5-62-51290	WIRE	\$ 248.87	UTILITY	DISTRIBUTION SYSTEM	R&M/DIST EQUIP/LINES/SVCS

VENDOR	ACCOUNT	DETAIL	AMOUNT	FUND	DEPARTMENT	ACCOUNT DESCRIPTION
ECHO ELECTRIC	60 -5-62-51290	DISTR SUPPLIES	\$ 55.92	UTILITY	DISTRIBUTION SYSTEM	R&M/DIST EQUIP/LINES/SVCS
ECHO ELECTRIC	60 -5-62-51290	DISTR SUPPLIES	\$ 540.50	UTILITY	DISTRIBUTION SYSTEM	R&M/DIST EQUIP/LINES/SVCS
ECHO ELECTRIC	60 -5-62-51290	DISTR SUPPLIES	\$ 77.48	UTILITY	DISTRIBUTION SYSTEM	R&M/DIST EQUIP/LINES/SVCS
ECHO ELECTRIC	60 -5-62-51290	WIRE	\$ 226.56	UTILITY	DISTRIBUTION SYSTEM	R&M/DIST EQUIP/LINES/SVCS
FLETCHER-REINHARDT COMP	60 -5-62-51290	COVER	\$ 3,101.50	UTILITY	DISTRIBUTION SYSTEM	R&M/DIST EQUIP/LINES/SVCS
FLETCHER-REINHARDT COMP	60 -5-62-51290	COVERS	\$ 735.00	UTILITY	DISTRIBUTION SYSTEM	R&M/DIST EQUIP/LINES/SVCS
FLETCHER-REINHARDT COMP	60 -5-62-51290	CONNECTORS	\$ 2,498.50	UTILITY	DISTRIBUTION SYSTEM	R&M/DIST EQUIP/LINES/SVCS
FLETCHER-REINHARDT COMP	60 -5-62-51290	ELEC SUPPLIES	\$ 5,695.71	UTILITY	DISTRIBUTION SYSTEM	R&M/DIST EQUIP/LINES/SVCS
FLETCHER-REINHARDT COMP	60 -5-62-51290	POLYSET BACKFILL SYSTM	\$ 1,253.47	UTILITY	DISTRIBUTION SYSTEM	R&M/DIST EQUIP/LINES/SVCS
FLETCHER-REINHARDT COMP	60 -5-62-51290	40 EYE PLATES/HOOKS	\$ 430.00	UTILITY	DISTRIBUTION SYSTEM	R&M/DIST EQUIP/LINES/SVCS
FLETCHER-REINHARDT COMP	60 -5-62-51290	ELEC SUPPLIES	\$ 7,101.75	UTILITY	DISTRIBUTION SYSTEM	R&M/DIST EQUIP/LINES/SVCS
FLETCHER-REINHARDT COMP	60 -5-62-51290	30 VERTICAL LINE POSTS	\$ 3,300.00	UTILITY	DISTRIBUTION SYSTEM	R&M/DIST EQUIP/LINES/SVCS
JOHN'S SERVICE & SALES	60 -5-62-51290	UNYTITE DR MNTNCE	\$ 473.05	UTILITY	DISTRIBUTION SYSTEM	R&M/DIST EQUIP/LINES/SVCS
ANIXTER INC	60 -5-62-51290	DISTR SUPPLIES	\$ 758.10	UTILITY	DISTRIBUTION SYSTEM	R&M/DIST EQUIP/LINES/SVCS
ADVANCED SANITATION	60 -5-62-51290	POLE DISPOSALS	\$ 2,940.56	UTILITY	DISTRIBUTION SYSTEM	R&M/DIST EQUIP/LINES/SVCS
VIPOWER SERVICES	60 -5-62-51290	XFRMR SVCS-UNYTITE N	\$ 483.75	UTILITY	DISTRIBUTION SYSTEM	R&M/DIST EQUIP/LINES/SVCS
S D P MANUFACTURING, IN	60 -5-62-51290	CYLINDER POLE GUIDE	\$ 348.31	UTILITY	DISTRIBUTION SYSTEM	R&M/DIST EQUIP/LINES/SVCS
FASTENAL CO	60 -5-62-65200	BLADES	\$ 40.20	UTILITY	DISTRIBUTION SYSTEM	OPERATING SUPPLIES
HALM'S MOTOR SERVICE	60 -5-62-65200	LIGHT BULB	\$ 1.49	UTILITY	DISTRIBUTION SYSTEM	OPERATING SUPPLIES
BATTERIES & THINGS	60 -5-62-65200	FLAT TOP	\$ 7.50	UTILITY	DISTRIBUTION SYSTEM	OPERATING SUPPLIES
TALLMAN EQUIPMENT CO	60 -5-62-65200	AERIAL APRON	\$ 274.00	UTILITY	DISTRIBUTION SYSTEM	OPERATING SUPPLIES
AMAZON CAPITAL SERVICES	60 -5-62-65200	SAFETY GLASSES-2 PAIR	\$ 76.52	UTILITY	DISTRIBUTION SYSTEM	OPERATING SUPPLIES
TALLMAN EQUIPMENT CO	60 -5-62-65210	GLOVE TESTING	\$ 308.36	UTILITY	DISTRIBUTION SYSTEM	SAFETY SUPPLIES
AMAZON CAPITAL SERVICES	60 -5-62-65210	WORK GLOVES 20 PAIR	\$ 1,150.40	UTILITY	DISTRIBUTION SYSTEM	SAFETY SUPPLIES
BATTERIES & THINGS	60 -5-62-65300	BATTERY CHARGER	\$ 195.00	UTILITY	DISTRIBUTION SYSTEM	SMALL TOOLS
BATTERIES & THINGS	60 -5-62-65300	JUMP STARTER	\$ 295.00	UTILITY	DISTRIBUTION SYSTEM	SMALL TOOLS
SHEARER TREE SERVICE	60 -5-64-51100	HYDRO FORESTY MOW	\$ 6,000.00	UTILITY	HYDROELECTRIC PLANT	R&M/BUILDINGS
MCMASER-CARR	60 -5-64-51200	PLASTIC FILTER HOUSING	\$ 214.62	UTILITY	HYDROELECTRIC PLANT	R&M/EQUIPMENT
CRANES & EQUIPMENT CORP	60 -5-64-51200	EQUIP MNTNCE	\$ 173.06	UTILITY	HYDROELECTRIC PLANT	R&M/EQUIPMENT
T & T HYDRAULICS	60 -5-64-51200	PARTS	\$ 15.48	UTILITY	HYDROELECTRIC PLANT	R&M/EQUIPMENT
ALBRECHT WELL DRILLING	60 -5-64-51200	HYDRO MNTNCE	\$ 442.50	UTILITY	HYDROELECTRIC PLANT	R&M/EQUIPMENT
TOEDTER OIL CO INC	60 -5-64-51200	DRUM OIL	\$ 1,156.00	UTILITY	HYDROELECTRIC PLANT	R&M/EQUIPMENT
CENTRAL MILLWRIGHT SERV	60 -5-64-51200	HYDRO TRASH RAKE INSTLL	\$ 232.10	UTILITY	HYDROELECTRIC PLANT	R&M/EQUIPMENT
COLOURS INC	60 -5-64-51200	RUST SEAL	\$ 47.00	UTILITY	HYDROELECTRIC PLANT	R&M/EQUIPMENT
WASTE MANAGEMENT CORP S	60 -5-64-52100	DUMPSTER SVC	\$ 136.76	UTILITY	HYDROELECTRIC PLANT	R&M/TRASH RACK
PEERLESS NETWORK	60 -5-64-56100	1128971 952 N 27TH	\$ 71.33	UTILITY	HYDROELECTRIC PLANT	TELEPHONE
MAZE LUMBER COMPANY	60 -5-64-65200	LUMBER	\$ 67.82	UTILITY	HYDROELECTRIC PLANT	OPERATING SUPPLIES

VENDOR	ACCOUNT	DETAIL	AMOUNT	FUND	DEPARTMENT	ACCOUNT DESCRIPTION
MAZE LUMBER COMPANY	60 -5-64-65200	LUMBER	\$ 50.99	UTILITY	HYDROELECTRIC PLANT	OPERATING SUPPLIES
TOEDTER OIL CO INC	60 -5-64-65200	KEROSENE	\$ 343.72	UTILITY	HYDROELECTRIC PLANT	OPERATING SUPPLIES
IL DEPT OF NATURAL RESO	60 -5-64-93000	2025 HYDRO LAND LEASE	\$ 2,500.00	UTILITY	HYDROELECTRIC PLANT	LICENSE/PERMITS
HYDRO PARTNERS	60 -5-64-93000	HYDRO REPORT FILING	\$ 2,150.00	UTILITY	HYDROELECTRIC PLANT	LICENSE/PERMITS
CHAPMAN'S MECHANICAL	60 -5-72-51100	AC SERVICE	\$ 191.25	UTILITY	WTP/WWTP	R&M BUILDINGS
KENDRICK PEST CONTROL I	60 -5-72-51100	DISPOSAL PLANT	\$ 35.00	UTILITY	WTP/WWTP	R&M BUILDINGS
KENDRICK PEST CONTROL I	60 -5-72-51100	WPWTP	\$ 35.00	UTILITY	WTP/WWTP	R&M BUILDINGS
SMITH'S SALES & SERVICE	60 -5-72-51200	OIL FILTER	\$ 16.00	UTILITY	WTP/WWTP	R&M EQUIPMENT
SMITH'S SALES & SERVICE	60 -5-72-51200	LINE	\$ 11.00	UTILITY	WTP/WWTP	R&M EQUIPMENT
SMITH'S SALES & SERVICE	60 -5-72-51200	PART	\$ 25.00	UTILITY	WTP/WWTP	R&M EQUIPMENT
UTILITY EQUIPMENT CO	60 -5-72-51200	WWTP PARTS	\$ 238.00	UTILITY	WTP/WWTP	R&M EQUIPMENT
UTILITY EQUIPMENT CO	60 -5-72-51200	WATER PLANT	\$ 358.00	UTILITY	WTP/WWTP	R&M EQUIPMENT
CENTRAL MILLWRIGHT SERV	60 -5-72-51200	CHANGE VALVES	\$ 1,883.52	UTILITY	WTP/WWTP	R&M EQUIPMENT
CENTRAL MILLWRIGHT SERV	60 -5-72-51200	FABRC 2 PVC SAVER TOOLS	\$ 98.00	UTILITY	WTP/WWTP	R&M EQUIPMENT
FERGUSON WATERWORKS	60 -5-72-51200	VALVES	\$ 540.46	UTILITY	WTP/WWTP	R&M EQUIPMENT
FERGUSON WATERWORKS	60 -5-72-51200	VALVES	\$ 594.56	UTILITY	WTP/WWTP	R&M EQUIPMENT
FERGUSON WATERWORKS	60 -5-72-51200	PVC/GASKETS	\$ 897.76	UTILITY	WTP/WWTP	R&M EQUIPMENT
FERGUSON WATERWORKS	60 -5-72-51200	PART	\$ 314.57	UTILITY	WTP/WWTP	R&M EQUIPMENT
INMAN ELECTRIC MOTORS,	60 -5-72-51200	MOTOR REPAIR	\$ 4,847.00	UTILITY	WTP/WWTP	R&M EQUIPMENT
TEST INC.	60 -5-72-52804	WATER & WWTP CONTRACT	\$ 23,681.61	UTILITY	WTP/WWTP	WS/WWTP SERVICE CONTRACT
CHAMLIN & ASSOCIATES IN	60 -5-72-53100	WELL 9 MNTNCE	\$ 890.00	UTILITY	WTP/WWTP	ENGINEERING
PEERLESS NETWORK	60 -5-72-56100	1128970 2901 PEORIA ST	\$ 148.17	UTILITY	WTP/WWTP	TELEPHONE
AIRGAS USA, LLC-NORTH D	60 -5-72-59310	CYLINDER LEASES	\$ 671.55	UTILITY	WTP/WWTP	EQUIPMENT RENTAL
MIDWEST SALT	60 -5-72-61300	SALT	\$ 3,352.50	UTILITY	WTP/WWTP	SALT
MIDWEST SALT	60 -5-72-61300	SALT	\$ 3,463.50	UTILITY	WTP/WWTP	SALT
MIDWEST SALT	60 -5-72-61300	SALT	\$ 3,118.50	UTILITY	WTP/WWTP	SALT
HAWKINS, INC	60 -5-72-62000	AZONE/SODIUM THIOSULFATE	\$ 3,341.90	UTILITY	WTP/WWTP	CHEMICALS FOR TREATMENT
HAWKINS, INC	60 -5-72-62000	AZONE	\$ 2,483.50	UTILITY	WTP/WWTP	CHEMICALS FOR TREATMENT
HAWKINS, INC	60 -5-72-62000	AZONE	\$ 2,310.00	UTILITY	WTP/WWTP	CHEMICALS FOR TREATMENT
HAWKINS, INC	60 -5-72-62000	AZONE	\$ 1,477.00	UTILITY	WTP/WWTP	CHEMICALS FOR TREATMENT
REPUBLIC SERVICES #792	60 -5-72-65010	WWTP WASTE CONTAINER	\$ 12,015.73	UTILITY	WTP/WWTP	SLUDGE REMOVAL
USA BLUEBOOK	60 -5-72-65200	ROLLER ASSEMBLY	\$ 594.13	UTILITY	WTP/WWTP	OPERATING SUPPLIES
AMEREN ILLINOIS	60 -5-72-66720	09973-76815 RT 6 WEST	\$ 65.16	UTILITY	WTP/WWTP	UTILITIES
AMEREN ILLINOIS	60 -5-72-66720	16520-07000 900 BRUNNER	\$ 88.65	UTILITY	WTP/WWTP	UTILITIES
AMEREN ILLINOIS	60 -5-72-66720	60154-25937 901 BRUNNER	\$ 65.16	UTILITY	WTP/WWTP	UTILITIES
MERTEL GRAVEL CO	60 -5-73-51520	CONCRETE	\$ 272.00	UTILITY	WATER DISTRIBUTION	R&M/WATER MAINS
MERTEL GRAVEL CO	60 -5-73-51520	CONCRETE	\$ 360.75	UTILITY	WATER DISTRIBUTION	R&M/WATER MAINS

VENDOR	ACCOUNT	DETAIL	AMOUNT	FUND	DEPARTMENT	ACCOUNT DESCRIPTION
MERTEL GRAVEL CO	60 -5-73-51520	CONCRETE	\$ 591.00	UTILITY	WATER DISTRIBUTION	R&M/WATER MAINS
MERTEL GRAVEL CO	60 -5-73-51520	CONCRETE	\$ 608.00	UTILITY	WATER DISTRIBUTION	R&M/WATER MAINS
MERTEL GRAVEL CO	60 -5-73-51520	CONCRETE	\$ 500.00	UTILITY	WATER DISTRIBUTION	R&M/WATER MAINS
MERTEL GRAVEL CO	60 -5-73-51520	CONCRETE	\$ 399.00	UTILITY	WATER DISTRIBUTION	R&M/WATER MAINS
MERTEL GRAVEL CO	60 -5-73-51520	FLOWABLE FILL	\$ 744.00	UTILITY	WATER DISTRIBUTION	R&M/WATER MAINS
FERGUSON WATERWORKS	60 -5-73-51520	COUPLINGS	\$ 4,015.57	UTILITY	WATER DISTRIBUTION	R&M/WATER MAINS
UTILITY EQUIPMENT CO	60 -5-73-51525	REPLC HIT HYDRNT	\$ 4,885.00	UTILITY	WATER DISTRIBUTION	R&M HYDRANTS
UTILITY EQUIPMENT CO	60 -5-73-51525	RPLC HYDRANT	\$ 3,938.00	UTILITY	WATER DISTRIBUTION	R&M HYDRANTS
UTILITY EQUIPMENT CO	60 -5-73-52000	MANHOLE CASTING	\$ 239.00	UTILITY	WATER DISTRIBUTION	R&M SEWERS
ADVANCED SANITATION	60 -5-73-52000	CLEAR 2 MANHOLES	\$ 1,000.00	UTILITY	WATER DISTRIBUTION	R&M SEWERS
CORE&MAIN	60 -5-73-52000	CLAMPS	\$ 773.50	UTILITY	WATER DISTRIBUTION	R&M SEWERS
FERGUSON WATERWORKS	60 -5-73-52960	METERS	\$ 5,055.72	UTILITY	WATER DISTRIBUTION	R&M METERS
FERGUSON WATERWORKS	60 -5-73-52960	GASKETS	\$ 268.95	UTILITY	WATER DISTRIBUTION	R&M METERS
FERGUSON WATERWORKS	60 -5-73-52960	METER SUPPLIES	\$ 6,792.18	UTILITY	WATER DISTRIBUTION	R&M METERS
PEERLESS NETWORK	60 -5-73-56100	1128982 1352 E ROCK ST	\$ 408.70	UTILITY	WATER DISTRIBUTION	TELEPHONE/INTERNET/CABLE
PEERLESS NETWORK	60 -5-73-56100	1128984 700 30TH ST	\$ 70.95	UTILITY	WATER DISTRIBUTION	TELEPHONE/INTERNET/CABLE
JOHN DEERE FINANCIAL	60 -5-73-65200	SUPPLIES	\$ 229.23	UTILITY	WATER DISTRIBUTION	OPERATING SUPPLIES
AMEREN ILLINOIS	60 -5-73-66720	78187-01938 2909 PEORIA ST	\$ 65.16	UTILITY	WATER DISTRIBUTION	UTILITIES
AMEREN ILLINOIS	60 -5-73-66720	86200-06895 BRUNNER ST	\$ 73.20	UTILITY	WATER DISTRIBUTION	UTILITIES
CIT TRUCKS-PERU 2650	60 -5-75-51300	E201 MNTNCE	\$ 626.74	UTILITY	TRUCKS & VEHICLES	R&M/VEHICLES
CIT TRUCKS-PERU 2650	60 -5-75-51300	E701 MNTNCE	\$ 1,149.58	UTILITY	TRUCKS & VEHICLES	R&M/VEHICLES
CIT TRUCKS-PERU 2650	60 -5-75-51300	E302 MNTNCE	\$ 11,250.74	UTILITY	TRUCKS & VEHICLES	R&M/VEHICLES
HALM'S MOTOR SERVICE	60 -5-75-51300	ENGINE CLEAN	\$ 27.96	UTILITY	TRUCKS & VEHICLES	R&M/VEHICLES
HALM'S MOTOR SERVICE	60 -5-75-51300	ENGINE CLEAN	\$ 27.96	UTILITY	TRUCKS & VEHICLES	R&M/VEHICLES
KING TIRE	60 -5-75-51300	E101 TIRES	\$ 810.00	UTILITY	TRUCKS & VEHICLES	R&M/VEHICLES
KING TIRE	60 -5-75-51300	TIRES	\$ 810.00	UTILITY	TRUCKS & VEHICLES	R&M/VEHICLES
KING TIRE	60 -5-75-51300	E101 TIRES	\$ 1,175.00	UTILITY	TRUCKS & VEHICLES	R&M/VEHICLES
JACK'S GAS & SERV INC	60 -5-75-51300	TRUCK INSPECTIONS	\$ 58.00	UTILITY	TRUCKS & VEHICLES	R&M/VEHICLES
TEREX CORPORATION	60 -5-75-51300	E301 PARTS	\$ 56.20	UTILITY	TRUCKS & VEHICLES	R&M/VEHICLES
TEREX CORPORATION	60 -5-75-51300	E301 PARTS	\$ 117.43	UTILITY	TRUCKS & VEHICLES	R&M/VEHICLES
CUSTOM TRUCK & EQUIPMEN	60 -5-75-51300	TRUCK MNTNCE	\$ 3,202.64	UTILITY	TRUCKS & VEHICLES	R&M/VEHICLES
WESTERN IL CUSTOM FIBER	60 -5-75-51300	BUCKET REPAIR	\$ 1,150.00	UTILITY	TRUCKS & VEHICLES	R&M/VEHICLES
RADIAN RESEARCH	60 -5-77-88000	METER LOAD TESTER	\$ 14,769.32	UTILITY	PLANT & EQUIPMENT	NEW EQUIPMENT
CUSTOM TRUCK CAPITAL	60 -5-77-88000	CS-37162/PAY 1 ACH	\$ 21,627.65	UTILITY	PLANT & EQUIPMENT	NEW EQUIPMENT
CHAMLIN & ASSOCIATES IN	60 -5-77-88408	AREA 2 PH1 SS	\$ 4,665.00	UTILITY	PLANT & EQUIPMENT	NEW WM (RT 6) 4TH ST
CHAMLIN & ASSOCIATES IN	60 -5-77-88435	EAKAS WM EXTENSION	\$ 15,857.50	UTILITY	PLANT & EQUIPMENT	EAKAS EXPANS INFRASTRC
MERTEL GRAVEL CO	60 -5-77-88435	ELEC CONCRETE BLOCKS W/HOOKS	\$ 5,000.00	UTILITY	PLANT & EQUIPMENT	EAKAS EXPANS INFRASTRC

VENDOR	ACCOUNT	DETAIL	AMOUNT	FUND	DEPARTMENT	ACCOUNT DESCRIPTION
FLETCHER-REINHARDT COMP	60 -5-77-88435	EAKAS EXPANSION	\$ 76,722.01	UTILITY	PLANT & EQUIPMENT	EAKAS EXPANS INFRASTRC
THOMASSON COMPANY	60 -5-77-88435	POLES EAKAS EXPANSION	\$ 23,100.00	UTILITY	PLANT & EQUIPMENT	EAKAS EXPANS INFRASTRC
TALLMAN EQUIPMENT CO	60 -5-77-88435	ELEC ROUND SLING	\$ 886.20	UTILITY	PLANT & EQUIPMENT	EAKAS EXPANS INFRASTRC
IL EPA-BUR WATER/PERMIT	60 -5-77-88435	EAKAS WM EXT	\$ 750.00	UTILITY	PLANT & EQUIPMENT	EAKAS EXPANS INFRASTRC
CHAMLIN & ASSOCIATES IN	60 -5-77-88450	WWTP UV REPLCMNT	\$ 1,740.00	UTILITY	PLANT & EQUIPMENT	WTP UPGRADES
SKI SEALCOATING & MAINT	60 -5-77-88500	AREA 2 PH 1 SS PAY4	\$ 220,360.76	UTILITY	PLANT & EQUIPMENT	SEWER SEPARATION PROJECTS
CHAMLIN & ASSOCIATES IN	60 -5-77-88512	WTR TWR PAINTING	\$ 534.00	UTILITY	PLANT & EQUIPMENT	GROUND STORAGE TANK PAINTG
CHAMLIN & ASSOCIATES IN	60 -5-77-88513	N TRUNK LINE SWR	\$ 178.00	UTILITY	PLANT & EQUIPMENT	TRUNK LINE-SEWER
MPOWER TECHNOLOGIES, IN	60 -5-77-88850	SYSTEM UPGRADES	\$ 4,000.00	UTILITY	PLANT & EQUIPMENT	SYSTEM UPGRADES
CENTRAL MILLWRIGHT SERV	60 -5-77-89830	STEEL PLATE FOR BREAKERS	\$ 325.60	UTILITY	PLANT & EQUIPMENT	WATER ST SUBSTATION
CHAMLIN & ASSOCIATES IN	60 -5-77-89831	HALM-DETENTION	\$ 28,310.50	UTILITY	PLANT & EQUIPMENT	MAY RD SUBSTATION
BHMG ENGINEERS	60 -5-77-89831	138KV INTERCONNECTION	\$ 26,758.49	UTILITY	PLANT & EQUIPMENT	MAY RD SUBSTATION
EDG CONSULTANTS LLC	85 -5-90-52650	RUNWAY LIGHT MNTNCE	\$ 2,000.00	AIRPORT	OPERATING EXPENSES	R&M RUNWYS/APRNS/HNGR FL
IV NET	85 -5-90-56100	OCT25 PORT CHARGES	\$ 50.00	AIRPORT	OPERATING EXPENSES	TELEPHONE
PEERLESS NETWORK	85 -5-90-56100	1128973-4251 ED URBAN DR	\$ 306.62	AIRPORT	OPERATING EXPENSES	TELEPHONE
AMEREN ILLINOIS	85 -5-90-57100	13710-62063 4260 ED URB	\$ 81.28	AIRPORT	OPERATING EXPENSES	UTILITIES
AMEREN ILLINOIS	85 -5-90-57100	61228-53139 PLNK RD	\$ 67.17	AIRPORT	OPERATING EXPENSES	UTILITIES
THE WEATHER COMPANY AVI	85 -5-90-59900	3 QTRLY RADAR SVC	\$ 525.00	AIRPORT	OPERATING EXPENSES	CONTRACTUAL SERVICE
Total Accts Payable Disbursements			\$ 2,950,061.67			

City of Peru Payroll Totals

GENERAL FUND	Payroll
10 ELECTED OFFICIALS	4,070.87
12 CLERK'S OFFICE	2,693.28
14 ENGINEER	16,960.93
15 ADMINISTRATIVE	1,255.36
16 POLICE	139,261.95
17 FIRE	29,523.58
19 STREET	29,014.00
22 BUILDING & GROUNDS	3,448.59
23 PARKS	8,295.66
24 CEMETERY	7,167.35
25 CITY GARAGE	6,884.71
26 FINANCE	10,500.39
27 IT	10,620.15
28 CORP COUNSEL	6,922.09
29 HUMAN RESOURCES	7,380.16
10 TOTAL GENERAL FUND	<u>\$ 283,999.07</u>
UTILITY FUND	
12 CLERK'S OFFICE	6,945.72
15 ADMINISTRATIVE	3,416.21
61 POWER & GENERATION	22,141.69
62 DISTRIBUTION SYSTEM	65,223.22
73 WATER DISTRIBUTION	36,616.99
60 TOTAL UTILITY FUND	<u>\$ 134,343.83</u>
TOTAL ALL PAYROLL EXPENSE	<u>\$ 418,342.90</u>



Post Office Box 299
Peru, Illinois 61354

October 16, 2025

Mayor Ken Kolowski,
Peru City Clerk, and
Aldermen of the City of Peru

RE: Petition of City of Peru
Final Plat of Halm Subdivision (PINs: 11-33-401-000 & 11-33-315-000)

Gentlemen:

Pursuant to legal notice published in the News Tribune in the manner provided by law, the Planning/Zoning Commission of the City of Peru convened for a public hearing on Wednesday, October 15, 2025, at 5:00 p.m. in the City Municipal Building, 1901 Fourth Street, Peru, IL, to consider the Petition of the City of Peru (“Petitioner”) concerning certain real estate commonly known as the “Halm Farm,” consisting of 73.125± acres generally located north of May Road and east of Illinois Route 251 in the City of Peru, Illinois, legally described as follows:

Parcel 1:

That part of the Southeast Quarter of Section 33, Township 34 North, Range 1 East of the Third Principal Meridian, which lies South and West of the LaSalle and Bureau County Railroad; situated in City of Peru, County of LaSalle and State of Illinois.

PARCEL IDENTIFICATION NUMBER: 11-33-401-000

Parcel 2:

The South Half of the Southwest Quarter of Section 33, Township 34 North, Range 1 East of the Third Principal Meridian, excepting 5.16 acres heretofore conveyed to the State of Illinois,

also excepting the West 16 acres thereof being described as the West 16 acres of the East 74.84 acres of the South Half of the Southwest Quarter in Said Section 33;

also excepting that part described as follows:

Commencing at the Southwest corner of the Southwest Quarter of said Section 33; thence North 90 degrees 00 minutes 00 seconds East 1032.56 feet along the South line of said Southwest Quarter to the Point of Beginning of the tract to be described; thence North 00 degrees 11 minutes 18 seconds East 570 feet to a point; thence South 90 degrees 00 minutes 00 seconds East 400 feet to a point; thence South 00 degrees 00 minutes 00 seconds West to a point on the South line of the Southwest Quarter of said Section 33;

thence South 90 degrees 00 minutes 00 seconds West to the point of beginning; situated in City of Peru, County of LaSalle and State of Illinois.
PARCEL IDENTIFICATION NUMBER: 11-33-315-000.
(collectively, the “Premises”).

The City seeks to subdivide the Premises and seeks the following relief, to wit: (1) approval of the Final Plat of Halm Subdivision, consisting of Five (5) Lots and One (1) Outlot; and (2) for such other and further relief deemed necessary or appropriate. A copy of the Final Plat is attached.

The Premises is zoned B-4 Highway Business District.

Planning/Zoning Commission Members Lucas, Jones, Grabowski, and Brady were present at the hearing. Chairman Miller and Members Kalsto and Becker were absent.

Petitioner’s Corporation Counsel, Scott Schweickert, testified that the City has been working together with Ameren on the Illinois Valley Reliability Project, which will involve the construction of a 138 kV Ameren substation upon Lot 1 of the proposed Halm Subdivision. Lot 2 will be the location of the City’s substation. Attorney Schweickert noted that City of Peru’s has pursued this development for decades, and it had always been planned to be built on the Premises.

Attorney Schweickert emphasized the importance of the project to the City. He noted the City currently receives power at 34.5 kV. Once the project is complete and the City is delivered power at 138 kV, there will be a significant increase in the capacity available in the City’s system to provide for future growth and development. Additionally, it will increase electric service reliability within the City’s system, and the City will enjoy substantial cost savings for its purchased power by avoiding transmission charges associated with stepping down the voltage to 34.5 kV. Attorney Schweickert thanked the City’s Electric Operations Manager, Kevin Minnick, and acknowledged that Minnick has been instrumental in bringing this project to fruition.

Attorney Schweickert testified further that he and the City’s Director of Engineering and Zoning, Eric Carls, have worked closely with the City’s consultant engineers, Chamlin and Associates, to design the proposed Final Plat of Halm Subdivision to address several things: the Ameren substation site, the City’s substation site, the easements needed for transmission lines and City utilities, and drainage. Schweickert noted the entire Premises is subject to a blanket drainage easement which requires the Premises to accept and drain stormwater from the Peru Marketplace retail area and detention pond to northwest, through the Premises to the southeast corner. A large detention pond will be constructed upon the 14.192± acre Outlot 1 to control the release rate of stormwater off the Premises. The City recently executed a contract to perform the mass grading work and that work will begin shortly.

Attorney Schweickert said the 23.315± acre Lot 3 is tucked in the back of the Premises and will make an ideal site for a complementary electric related development, whether that be community solar, battery storage, or something else. Lot 4 (3.414± acres) and Lot 5 (8.215± acres) are platted along the May Road frontage for future retail or other development consistent with B-4 Zoning and the surrounding area.

In response to questioning from Member Lucas, City Director of Engineering and Zoning, Eric Carls, noted there are two unnamed roadways on the subdivision plat. The north/south road runs along the west side of the substation sites and will be permitted through IDOT. Ameren will have a separately permitted access point directly to Lot 1 from May Road. The unnamed east/west road is designed to potentially connect to the Peru Marketplace Subdivision in the future, just south of Petsmart. Engineer Carls indicated that, in the future, the City may also have an access point to the regional detention facility on Outlot 1, which may end up being another City park.

Member Lucas said he always figured drainage would be a problem in that area and said the big pond will be a nice addition. Engineer Carls said the pond would be built in phases. The first phase will be about 8 acres but eventually end up around 12 acres in size.

In response to questioning from Member Grabowski, Engineer Carls said typically when a development is planned for a site has been filled with material, the fill will be classified as undocumented fill and is often required to be removed. Accordingly, instead of mass grading Lots 3, 4, and 5 and having the topsoil classified as undocumented fill, the City intends to stockpile dirt on the north side of the pond on Outlot 1. When those lots are purchased for development, fill material will be available in close proximity to the site for testing and use. As the stockpile depletes, the pond will be expanded.

John Lamps was in attendance at the meeting. Mr. Lamps said his interest is in the tile and drainage on the Premises, and that he had multiple discussions with Engineer Carls during the planning process. Attorney Schweickert noted that Mr. Lamps is the City's tenant farmer for the Premises and does a great job working with the City. Mr. Lamps said his family has owned a farm north of the Premises since 1910, and all the drainage tile routes south through the Premises. Engineer Carls said the City executed a mass grading contract and he has been tracking Lamp's progress with harvest of this year's crops. It is anticipated that they will begin stripping topsoil next week. They will also pothole a couple locations of the drainage tile to evaluate whether they will be able to run it into the pond or need to reroute it around the pond to the outlet. Lamps said harvest should be complete this weekend.

There were no public comments or objections.

The Planning/Zoning Commission found the requested relief will not alter the essential character of the locality; will not be detrimental or injurious to other properties in the area; will not impair an adequate supply of light or air to adjacent properties, or increase the danger of fire, or endanger the public safety, or diminish or impair property values and will not increase street congestion and, therefore, favorably recommends that the City Council grant the relief as prayed for in the Petition.

Member Lucas moved, and Member Jones seconded, to favorably recommend that the City Council approve the Petition as prayed for. The motion passed unanimously: 4 aye, 0 nay, and 3 Members absent.

Respectfully submitted,

CARY MILLER, Chairman
Planning/Zoning Commission

FINAL PLAT OF HALM SUBDIVISION

IN THE CITY OF PERU, LA SALLE COUNTY, ILLINOIS
BEING A PART OF THE SOUTH HALF OF SECTION 33, T. 34 N., R. 1 E. OF THE 3RD P.M.
73.125 ± ACRES

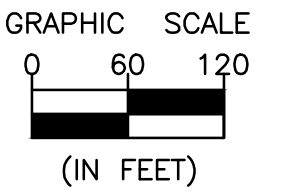

LEGEND	
	BOUNDARY OF SUBDIVISION
	SECTION LINE
	LOT LINE
	BUILDING SETBACK LINE
	RIGHT OF WAY LINE
	EASEMENT LINE
	EXISTING IRON PIPE
	ROW
	P.U.E.
	RIGHT OF WAY
	PUBLIC UTILITY EASEMENT

OWNER / SUBDIVIDER

CITY OF PERU
 1901 4TH STREET
 PERU, IL 61354

ENGINEER / SURVEYOR

CHAMLIN & ASSOCIATES, INC.
 4152 PROGRESS BLVD.
 PERU, IL 61354
 (815)223-3344

ZONING SUMMARY

B-4, HIGHWAY BUSINESS DISTRICT

BUILDING SETBACK SUMMARY

FRONT SETBACK: 40 FEET
 REAR SETBACK: 40 FEET
 SIDE SETBACK: 20 FEET, EXCEPT A SIDE YARD ADJOINING
 A STREET SHALL BE 40 FEET

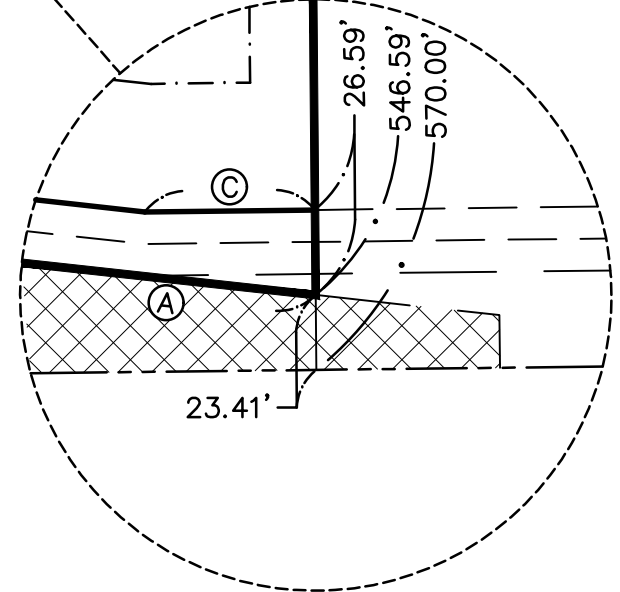
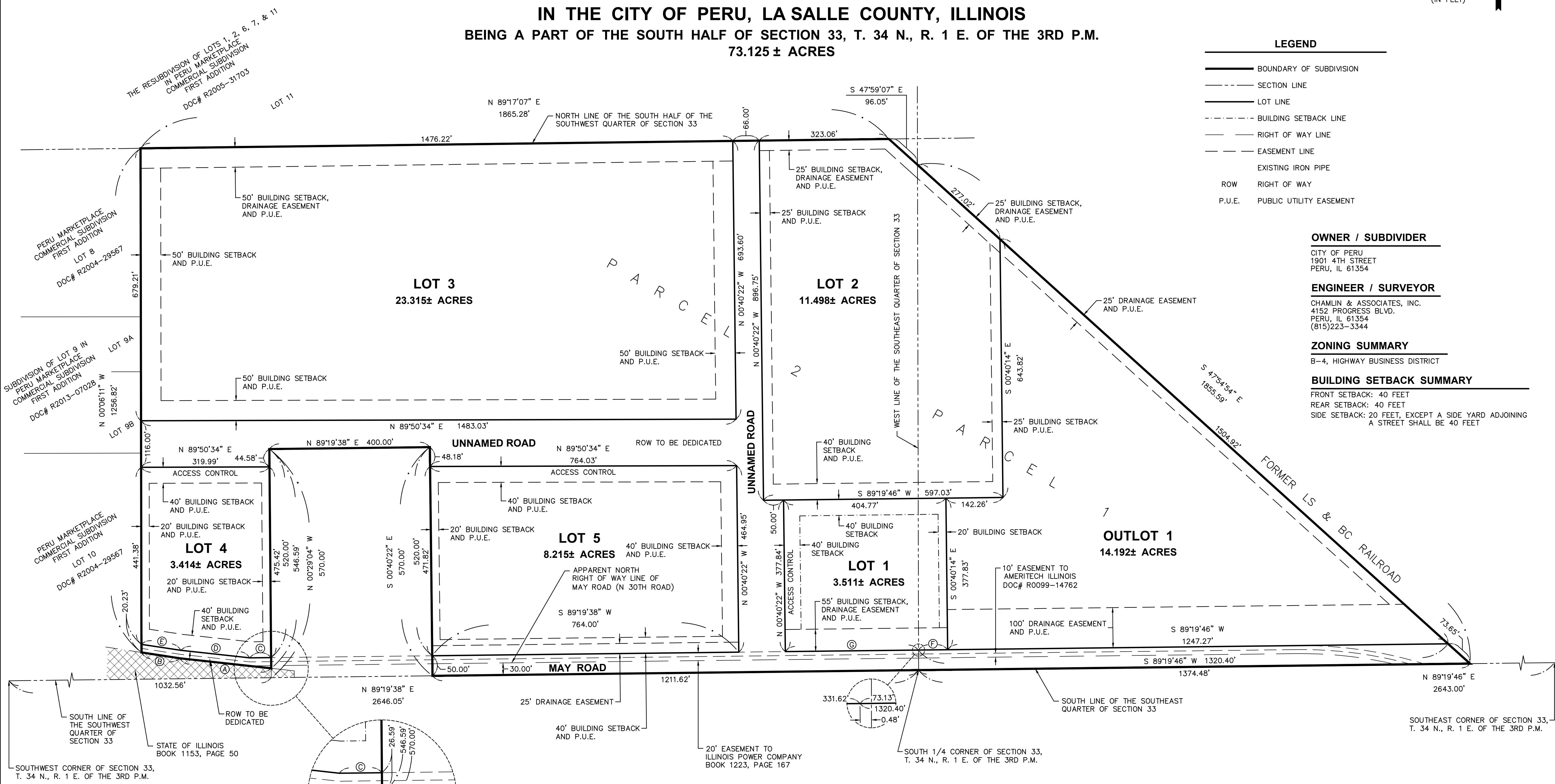

Ⓐ N 83°45'10" W 229.09'	Ⓓ N 83°45'10" W 172.78'	Ⓒ S 89°19'38" W 331.62'
Ⓑ N 81°20'17" W 96.77'	Ⓔ N 81°20'17" W 99.44'	
Ⓒ S 89°19'38" W 53.16'	Ⓕ S 89°19'46" W 73.13'	

NOTES:

PARCELS 1 & 2 ARE SUBJECT TO A BLANKET EASEMENT FOR STORMWATER DRAINAGE DOC# R2006-09655
 TOTAL ROW TO BE DEDICATED 8,980 ± ACRES
 IRON PIPE SET ALL LOT CORNERS UNLESS NOTED OTHERWISE.

4152 Progress Blvd
 Peru, IL 61354
 815.223.3344
 www.chamlin.com
 Professional Design Firm
 License # 184-001717
 © Copyright 2025
 All Rights Reserved

FINAL PLAT		DATE:
BEING A PART OF THE SOUTH HALF OF SECTION 33, T. 34 N., R. 1 E. OF THE 3RD P.M.		10/15/2025
		FIELDWORK: 08/2025
PREPARED FOR:		REVISIONS:
CITY OF PERU		DRAWN BY: LAG
		CHECKED BY: MSR
		JOB NUMBER: 15553.00
		SHEET 1 OF 2

G:\Users\15155533\OneDrive\Regional\Deliverables\CAD\FINAL PLAT - 15553.00.dwg

FINAL PLAT OF HALM SUBDIVISION

IN THE CITY OF PERU, LA SALLE COUNTY, ILLINOIS

BEING A PART OF THE SOUTH HALF OF SECTION 33, T. 34 N., R. 1 E. OF THE 3RD P.M.
73.125 ± ACRES

SURVEYOR'S CERTIFICATE

This is to certify that I, Michael S. Richetta, Professional Land Surveyor No. 035-003788, have surveyed and subdivided the following property:

Parcel 1

That part of the Southeast Quarter of Section 33, Township 34 North, Range 1 East of the Third Principal Meridian, which lies south and west of the former LaSalle and Bureau County (LS & BC) Railroad, in the Dimmick Township, LaSalle County, Illinois.

Parcel 2

The South Half of the Southwest Quarter of Section 33, Township 34 North, Range 1 East of the Third Principal Meridian, LaSalle County, Illinois, excepting 5.16 acres heretofore conveyed to the State of Illinois,

also excepting the West 16 acres thereof being described as the West 16 acres of the East 74.84 acres of the South Half of the Southwest Quarter in said Section 33,

also excepting that part described as follows:

Commencing at the Southwest Corner of the Southwest Quarter of said Section 33; thence North 90° 00' 00" East, 1032.56 feet along the South line of said Southwest Quarter to the Point of Beginning of the tract to be described; thence North 00° 11' 18" East, 570 feet to a point; thence South 90° 00' 00" East, 400 feet to a point; thence South 00° 00' 00" West to a point on the South line of the Southwest Quarter of said Section 33; thence South 90° 00' 00" West to the Point of Beginning.

I further certify that no part of this subdivision lies within a Special Flood Hazard Area as identified by the Federal Emergency Management Agency (FEMA) on their Flood Insurance Rate No. 17099C0480F effective date 07/18/2011.

Given under my hand and seal at Peru, Illinois, this _____ day of _____, A.D., _____.

Michael S. Richetta
Professional Land Surveyor No. 035-003788



DRAINAGE CERTIFICATE

STATE OF ILLINOIS)
COUNTY OF LASALLE) SS

We, Michael W. Perry, a Professional Engineer, duly licensed under the laws of the State of Illinois, and the City of Peru, Illinois, designated representative of the City of Peru, Illinois do hereby certify to the best of our knowledge and belief that Halm Subdivision, City of Peru, Illinois, has been designed so that there is no change in the drainage of surface water by the construction of said subdivision or any part thereof, or that if such surface water drainage is changed, reasonable provision has been made for collection and diversion of such surface waters so that the adjoining land will not be damaged.

Dated this _____ day of _____, A.D., _____.

Michael W. Perry
P.E. No. 062-054006

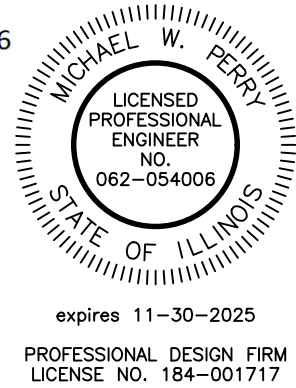

Designated Representative
City of Peru

OWNER'S CERTIFICATE

STATE OF ILLINOIS)
COUNTY OF LASALLE) SS

We, the undersigned, City of Peru, Designated Representative, of the premises described in the Surveyor's Certificate hereon, do hereby certify that we have caused said property above set forth to be surveyed and platted by Michael S. Richetta, a Professional Land Surveyor, as shown on the above plat into lots and roadways as shown thereon, and that all deeds or other conveyances of said lots or any part thereof, hereafter made shall have reference to the above plat.

We further certify that we have named said plat "Halm Subdivision, City of Peru, Illinois," and have named the roadways as designated thereon and do hereby join and consent to said plat being presented to the City Council of the City of Peru for adoption and having the same recorded as provided by law.

We further certify that all roadways shown thereon and therein contained are dedicated to the City and to the public use and we further release and waive all rights under and by virtue of the Homestead Exemption Laws of the State of Illinois in and to said roadways shown on plat.

The City, for itself, its successors, assigns and permittees, reserves, creates and grants to the City the following perpetual rights and easements in, over, under, across, along, and upon those portions of the plat designated "Utility Easements" (hereinafter "Easement Tracts"):

- a. To construct, operate, repair, maintain, patrol, inspect, relocate, reconstruct and remove, from time to time, electric transmission, distribution and communication lines and systems, including, but not limited to, overhead cables, conduits, conductors, grounds, drains, necessary service pedestals, transformer cabinets, concrete transformer pads, transformer riser poles and conduits, associated overhead supply lines, and other equipment appurtenant thereto and, without limitation, such other installations as may be required or may be deemed necessary by the City for electrical system purposes;
- b. To construct, operate, repair, maintain, patrol, inspect, relocate, reconstruct and remove, from time to time, sanitary sewers, storm sewers and any and all manholes, tiles, pipes, connections, catch basins and, without limitation, such other installations as may be required or may be deemed necessary by the City for sanitary and/or storm sewer purposes; and
- c. To construct, operate, repair, maintain, patrol, inspect, relocate, reconstruct and remove, from time to time, water mains and lines, and any and all necessary manholes, hydrants, pipes, connections, buffalo boxes and, without limitation, such other installations as may be required or may be deemed necessary by the City for water services purposes.

The aforesaid perpetual rights and easements are reserved, created and granted together with the right (i) to use adjacent roads, streets and alleys for such purposes and to use reasonable working space adjacent to said Easement Tracts during construction or maintenance of said utility system; (ii) to control the growth of any vegetation, trees, shrubs, or saplings on the Easement Tracts; and (iii) to clear and remove, without any liability, any obstacles on the Easement Tracts which interfere or threaten to interfere with the safe and proper construction, operation, and maintenance of any said utility system on the Easement Tracts or which creates hazardous conditions, and to keep the Easement Tracts clear of such obstacles and obstructions. The City shall have the right to clear and remove any such obstacles, but not the obligation to do so.

Subsequent owners may make any use of the Easement Tracts, so long as such use does not interfere with the rights herein reserved or create a hazardous condition, except that the subsequent owners shall make no excavations on the Easement Tracts without the prior consent of the City and then only in such manner as will not disturb or interfere with the City's facilities located therein, nor shall the subsequent owners place buildings or structures on the

Easement Tracts. Subsequent owners may pave entranceways over the Easement Tracts. Notwithstanding the contrary in this Easement, the City shall not interfere with any ingress or egress over or upon any roadways on the said Easement Tracts.

IN WITNESS WHEREOF, we have hereunto set our hand and seal this _____ day of _____, A.D., _____.

Designated Representative
City of Peru

NOTARY PUBLIC

STATE OF ILLINOIS)
COUNTY OF LASALLE) SS

I, _____, a Notary Public in and for said County, in the State aforesaid, do hereby certify that the City of Peru, Designated Representative personally known to me to be the Owner, whose name is subscribed to the foregoing instrument, appeared before me this day in person and severally acknowledged that as such, he/she signed and delivered the said instrument of writing as their and voluntary act and deed, for the uses and purposes set forth.

Given under my hand and notarial seal this _____ day of _____, A.D., _____.

Notary Public

SCHOOL DISTRICT CERTIFICATE

STATE OF ILLINOIS)
COUNTY OF LASALLE) SS

We, the City of Peru, Designated Representative, Owner of the property herein described in the Surveyor's Certificate, do hereby certify that "Halm Subdivision, City of Peru, Illinois," to the best of our knowledge, is located within the boundaries of Dimmick Comm. Cons. School District #175, LaSalle-Peru Township High School #120, and Illinois Valley Community College School District #513 in LaSalle County, Illinois.

Dated this _____ day of _____, A.D., _____.

Designated Representative

IDOT CERTIFICATE

This plat has been approved by the Illinois Department of Transportation with respect to roadway access pursuant to 765 ILCS 205/2, as amended. However, a Highway Permit for access is required by the Owner of the property. A plan that meets the requirements contained in the Department's "Policy on Permits for Access Driveways to State Highways" will be required by the Department.

Date: _____
Region 2 Engineer

CITY CERTIFICATES

STATE OF ILLINOIS)
COUNTY OF LASALLE) SS
CITY OF PERU)

Approved and accepted by the Council of the City of Peru, this _____ day of _____, A.D., _____, by Ordinance No. _____ on file with the City Clerk of Peru, Illinois, entitled "An Ordinance Approving the Plat of "Halm Subdivision, City of Peru, Illinois" as follows:

BE IT ORDAINED BY THE CITY COUNCIL OF THE CITY OF PERU, LASALLE COUNTY, ILLINOIS, A HOME RULE MUNICIPALITY, AS FOLLOWS:

Section 1: That the plat of the Halm Subdivision, City of Peru, Illinois, as made by Michael S. Richetta, Professional Land Surveyor, under and by direction of the City of Peru of the premises described and platted herein, and the same is hereby approved and accepted.

Section 2: That this Ordinance shall be in full force and effect from and after its passage and approval thereof.

The above Ordinance was adopted at a meeting of the City Council of the City of Peru, Illinois, held on the _____ day of _____, A.D., _____, with _____ Aldermen voting "Aye" and _____ Aldermen voting "Nay" and the Mayor voting _____.

Jamey Mertel, City Clerk
City of Peru, Illinois

Approved by the Mayor of the City of Peru this _____ day of _____, A.D., _____.

Kenneth Kolowski, Mayor
City of Peru, Illinois

Approved by the Planning/Zoning Commission of the City of Peru, Illinois, on the _____ day of _____, A.D., _____.

Chairman
STATE OF ILLINOIS)
COUNTY OF LASALLE) SS
CITY OF PERU)

I, Jamey Mertel, City Clerk of the City of Peru, Illinois, do hereby certify that there are no unpaid special assessments or special taxes levied against the tract of land or any part thereof in the plat on which this Certificate is attached.

Dated this _____ day of _____, A.D., _____.

Jamey Mertel, City Clerk
City of Peru, Illinois

COUNTY CERTIFICATE

STATE OF ILLINOIS)
COUNTY OF LASALLE) SS

I, Jennifer Ebner, County Clerk of LaSalle County, Illinois, do hereby certify that I have examined the record of said County, that I find no delinquent general taxes, unpaid current general taxes, delinquent special assessments or unpaid current special assessments against the tract of land, or any part thereof, in the plat to which this is attached.

Given under my hand and official seal this _____ day of _____, A.D., _____.

Jennifer Ebner, County Clerk

TAX CODE NO(S): 11-77-333-001, 11-77-433-001

 Chamlin & Associates ENGINEERS • SURVEYORS • PLANNERS	4152 Progress Blvd Peru, IL 61354 815.223.3344 www.chamlin.com Professional Design Firm License # 184-001717 © Copyright 2025 All Rights Reserved	FINAL PLAT BEING A PART OF THE SOUTH HALF OF SECTION 33, T. 34 N., R. 1 E. OF THE 3RD P.M.	DATE: 10/15/2025 FIELDWORK: 08/2025 REVISED DRAWN BY: LAG CHECKED BY: MSR JOB NUMBER: 15553.00
	PREPARED FOR: CITY OF PERU	SHEET 2 OF 2	

ORDINANCE NO. _____

AN ORDINANCE APPROVING AND ACCEPTING THE FINAL PLAT OF HALM SUBDIVISION TO THE CITY OF PERU AS SOUGHT BY THE PETITION OF THE CITY OF PERU, ILLINOIS

WHEREAS, after legal ad notice duly published in the News Tribune in the manner provided by law, the City of Peru Planning/Zoning Commission convened for a public hearing on October 15, 2025, to consider the Petition of the City of Peru (“Petitioner”), concerning certain real estate generally located commonly known as the “Halm Farm,” consisting of 73.125± acres generally located north of May Road and east of Illinois Route 251 in the City of Peru, Illinois, legally described as follows:

Parcel 1:

That part of the Southeast Quarter of Section 33, Township 34 North, Range 1 East of the Third Principal Meridian, which lies South and West of the LaSalle and Bureau County Railroad; situated in City of Peru, County of LaSalle and State of Illinois.
PARCEL IDENTIFICATION NUMBER: 11-33-401-000

Parcel 2:

The South Half of the Southwest Quarter of Section 33, Township 34 North, Range 1 East of the Third Principal Meridian, excepting 5.16 acres heretofore conveyed to the State of Illinois,

also excepting the West 16 acres thereof being described as the West 16 acres of the East 74.84 acres of the South Half of the Southwest Quarter in Said Section 33;

also excepting that part described as follows:

Commencing at the Southwest corner of the Southwest Quarter of said Section 33; thence North 90 degrees 00 minutes 00 seconds East 1032.56 feet along the South line of said Southwest Quarter to the Point of Beginning of the tract to be described; thence North 00 degrees 11 minutes 18 seconds East 570 feet to a point; thence South 90 degrees 00 minutes 00 seconds East 400 feet to a point; thence South 00 degrees 00 minutes 00 seconds West to a point on the South line of the Southwest Quarter of said Section 33; thence South 90 degrees 00 minutes 00 seconds West to the point of beginning; situated in City of Peru, County of LaSalle and State of Illinois.
PARCEL IDENTIFICATION NUMBER: 11-33-315-000.

(collectively, the “Premises”); and

WHEREAS, Petitioner, as owner of the Premises, desires to subdivide the Premises and seeks the approval of the Final Plat of Halm Subdivision, consisting of Five (5) Lots and One (1) Outlot; and

WHEREAS, the Planning/Zoning Commission has made its report of the hearing and has unanimously recommended that the City Council approve the Petition as prayed for.

NOW, THEREFORE, BE IT ORDAINED BY THE CITY COUNCIL OF THE CITY OF PERU, A HOME RULE MUNICIPALITY, AS FOLLOWS:

SECTION 1: The City Council finds as facts the recitals hereinbefore set forth and incorporates them herein by reference.

SECTION 2: The City Council hereby approves and accepts the Final Plat of Halm Subdivision to the City of Peru, Illinois, as prepared by Chamlin & Associates, Inc. dated October 15, 2025, a copy of which is attached hereto and incorporated herein. Said Final Plat of Halm Subdivision shall be recorded with the LaSalle County Recorder.

SECTION 3: This Ordinance shall be in full force and effect from and after its passage and approval according to law.

PRESENTED, PASSED, AND ADOPTED at a regular meeting of the City Council of the City of Peru, Illinois, by an aye and nay roll call vote, with _____ voting aye, _____ voting nay, _____ absent, and Mayor Kolowski _____ voting _____, which meeting was held on the 20th day of October, 2025.

APPROVED: October 20, 2025

Ken Kolowski, Mayor

(CORPORATE SEAL)

ATTEST:

Jamey Mertel, City Clerk

Aldermen Aye Nay Absent
Ballard
Tieman
Payton
Edgcomb
O'Sadnick
Sapienza
Lukosus
Moreno

FINAL PLAT OF HALM SUBDIVISION

IN THE CITY OF PERU, LA SALLE COUNTY, ILLINOIS
BEING A PART OF THE SOUTH HALF OF SECTION 33, T. 34 N., R. 1 E. OF THE 3RD P.M.
73.125 ± ACRES

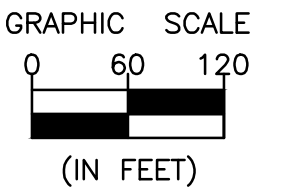

LEGEND	
	BOUNDARY OF SUBDIVISION
	SECTION LINE
	LOT LINE
	BUILDING SETBACK LINE
	RIGHT OF WAY LINE
	EASEMENT LINE
	EXISTING IRON PIPE
	ROW
	P.U.E.

OWNER / SUBDIVIDER

CITY OF PERU
1901 4TH STREET
PERU, IL 61354

ENGINEER / SURVEYOR

CHAMLIN & ASSOCIATES, INC.
4152 PROGRESS BLVD.
PERU, IL 61354
(815)223-3344

ZONING SUMMARY

B-4, HIGHWAY BUSINESS DISTRICT

BUILDING SETBACK SUMMARY

FRONT SETBACK: 40 FEET
REAR SETBACK: 40 FEET
SIDE SETBACK: 20 FEET, EXCEPT A SIDE YARD ADJOINING A STREET SHALL BE 40 FEET

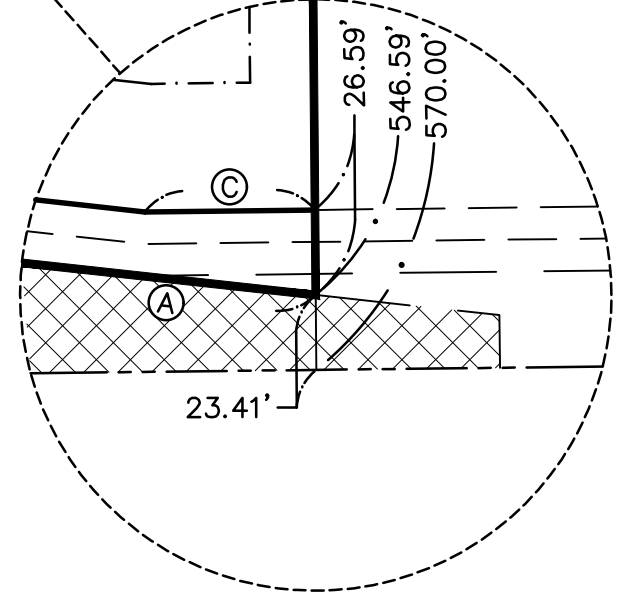
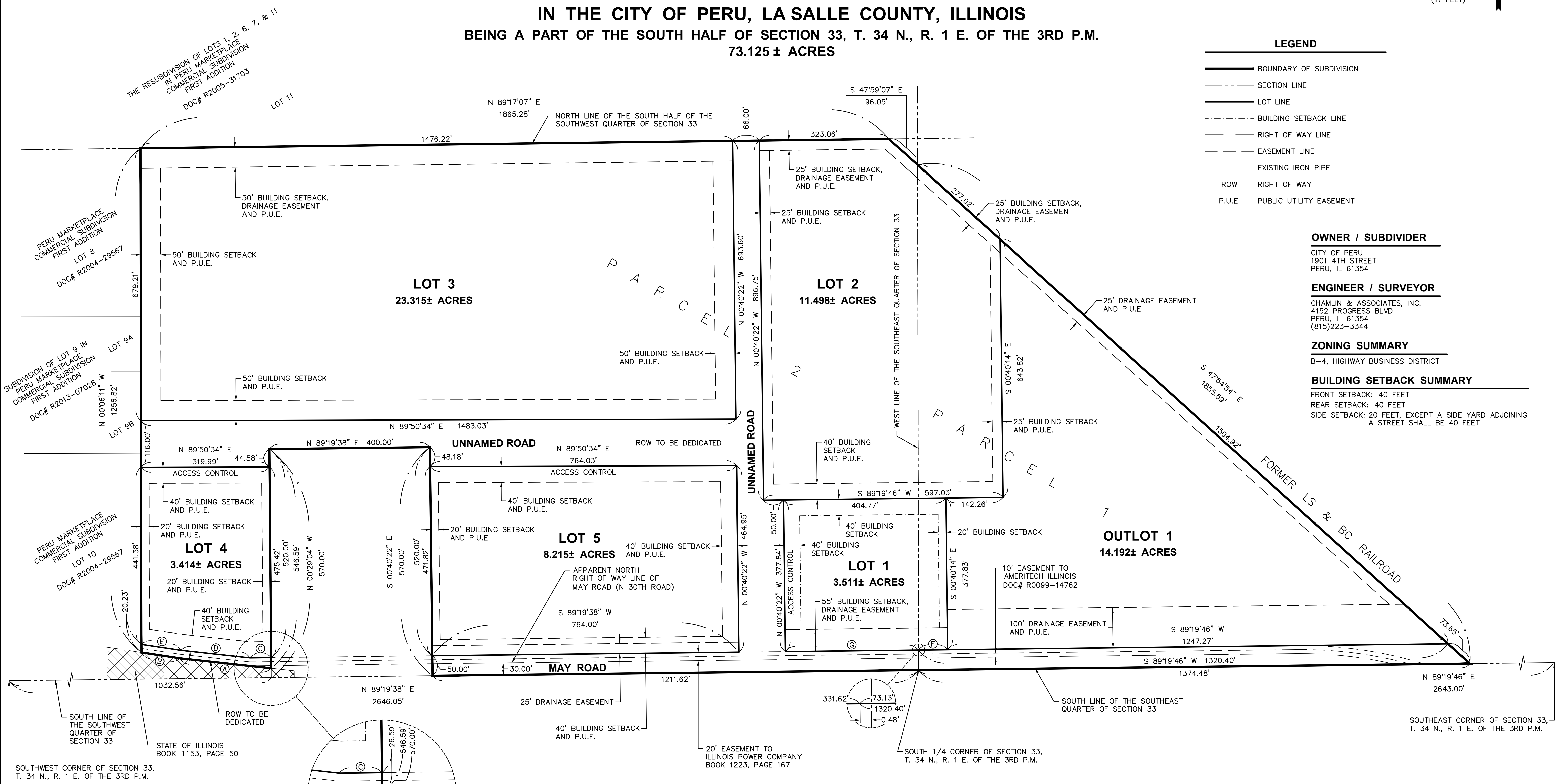

Ⓐ N 83°45'10" W 229.09'	Ⓓ N 83°45'10" W 172.78'	Ⓒ S 89°19'38" W 331.62'
Ⓑ N 81°20'17" W 96.77'	Ⓔ N 81°20'17" W 99.44'	
Ⓒ S 89°19'38" W 53.16'	Ⓕ S 89°19'46" W 73.13'	

NOTES:

PARCELS 1 & 2 ARE SUBJECT TO A BLANKET EASEMENT FOR STORMWATER DRAINAGE DOC# R2006-09655
TOTAL ROW TO BE DEDICATED 8,980 ± ACRES
IRON PIPE SET ALL LOT CORNERS UNLESS NOTED OTHERWISE.

4152 Progress Blvd
Peru, IL 61354
815.223.3344
www.chamlin.com
Professional Design Firm
License # 184-001717
© Copyright 2025
All Rights Reserved

FINAL PLAT		DATE:
BEING A PART OF THE SOUTH HALF OF SECTION 33, T. 34 N., R. 1 E. OF THE 3RD P.M.		10/15/2025
		FIELDWORK: 08/2025
PREPARED FOR:		REVISION:
CITY OF PERU		DRAWN BY: LAG
		CHECKED BY: MSR
		JOB NUMBER: 15553.00
		SHEET 1 OF 2

G:\Users\15155533\OneDrive\Regional\Deliverables\CAD\FINAL PLAT - 15553.dwg

FINAL PLAT OF HALM SUBDIVISION

IN THE CITY OF PERU, LA SALLE COUNTY, ILLINOIS

BEING A PART OF THE SOUTH HALF OF SECTION 33, T. 34 N., R. 1 E. OF THE 3RD P.M. 73.125 ± ACRES

SURVEYOR'S CERTIFICATE

This is to certify that I, Michael S. Richetta, Professional Land Surveyor No. 035-003788, have surveyed and subdivided the following property:

Parcel 1

That part of the Southeast Quarter of Section 33, Township 34 North, Range 1 East of the Third Principal Meridian, which lies south and west of the former LaSalle and Bureau County (LS & BC) Railroad, in the Dimmick Township, LaSalle County, Illinois.

Parcel 2

The South Half of the Southwest Quarter of Section 33, Township 34 North, Range 1 East of the Third Principal Meridian, LaSalle County, Illinois, excepting 5.16 acres heretofore conveyed to the State of Illinois,

also excepting the West 16 acres thereof being described as the West 16 acres of the East 74.84 acres of the South Half of the Southwest Quarter in said Section 33,

also excepting that part described as follows:

Commencing at the Southwest Corner of the Southwest Quarter of said Section 33; thence North 90° 00' 00" East, 1032.56 feet along the South line of said Southwest Quarter to the Point of Beginning of the tract to be described; thence North 00° 11' 18" East, 570 feet to a point; thence South 90° 00' 00" East, 400 feet to a point; thence South 00° 00' 00" West to a point on the South line of the Southwest Quarter of said Section 33; thence South 90° 00' 00" West to the Point of Beginning.

I further certify that no part of this subdivision lies within a Special Flood Hazard Area as identified by the Federal Emergency Management Agency (FEMA) on their Flood Insurance Rate No. 17099C0480F effective date 07/18/2011.

Given under my hand and seal at Peru, Illinois, this _____ day of _____, A.D., _____.

Michael S. Richetta
Professional Land Surveyor No. 035-003788



DRAINAGE CERTIFICATE

STATE OF ILLINOIS)
COUNTY OF LASALLE) SS

We, Michael W. Perry, a Professional Engineer, duly licensed under the laws of the State of Illinois, and the City of Peru, Illinois, designated representative of the City of Peru, Illinois do hereby certify to the best of our knowledge and belief that Halm Subdivision, City of Peru, Illinois, has been designed so that there is no change in the drainage of surface water by the construction of said subdivision or any part thereof, or that if such surface water drainage is changed, reasonable provision has been made for collection and diversion of such surface waters so that the adjoining land will not be damaged.

Dated this _____ day of _____, A.D., _____.

Michael W. Perry
P.E. No. 062-054006

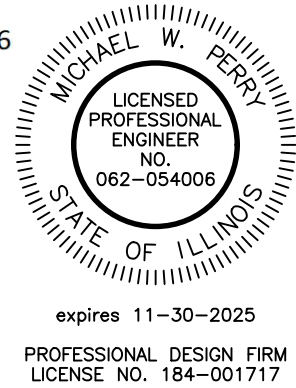

Designated Representative
City of Peru

OWNER'S CERTIFICATE

STATE OF ILLINOIS)
COUNTY OF LASALLE) SS

We, the undersigned, City of Peru, Designated Representative, of the premises described in the Surveyor's Certificate hereon, do hereby certify that we have caused said property above set forth to be surveyed and platted by Michael S. Richetta, a Professional Land Surveyor, as shown on the above plat into lots and roadways as shown thereon, and that all deeds or other conveyances of said lots or any part thereof, hereafter made shall have reference to the above plat.

We further certify that we have named said plat "Halm Subdivision, City of Peru, Illinois," and have named the roadways as designated thereon and do hereby join and consent to said plat being presented to the City Council of the City of Peru for adoption and having the same recorded as provided by law.

We further certify that all roadways shown thereon and therein contained are dedicated to the City and to the public use and we further release and waive all rights under and by virtue of the Homestead Exemption Laws of the State of Illinois in and to said roadways shown on plat.

The City, for itself, its successors, assigns and permittees, reserves, creates and grants to the City the following perpetual rights and easements in, over, under, across, along, and upon those portions of the plat designated "Utility Easements" (hereinafter "Easement Tracts"):

- a. To construct, operate, repair, maintain, patrol, inspect, relocate, reconstruct and remove, from time to time, electric transmission, distribution and communication lines and systems, including, but not limited to, overhead cables, conduits, conductors, grounds, drains, necessary service pedestals, transformer cabinets, concrete transformer pads, transformer riser poles and conduits, associated overhead supply lines, and other equipment appurtenant thereto and, without limitation, such other installations as may be required or may be deemed necessary by the City for electrical system purposes;
- b. To construct, operate, repair, maintain, patrol, inspect, relocate, reconstruct and remove, from time to time, sanitary sewers, storm sewers and any and all manholes, tiles, pipes, connections, catch basins and, without limitation, such other installations as may be required or may be deemed necessary by the City for sanitary and/or storm sewer purposes; and
- c. To construct, operate, repair, maintain, patrol, inspect, relocate, reconstruct and remove, from time to time, water mains and lines, and any and all necessary manholes, hydrants, pipes, connections, buffalo boxes and, without limitation, such other installations as may be required or may be deemed necessary by the City for water services purposes.

The aforesaid perpetual rights and easements are reserved, created and granted together with the right (i) to use adjacent roads, streets and alleys for such purposes and to use reasonable working space adjacent to said Easement Tracts during construction or maintenance of said utility system; (ii) to control the growth of any vegetation, trees, shrubs, or saplings on the Easement Tracts; and (iii) to clear and remove, without any liability, any obstacles on the Easement Tracts which interfere or threaten to interfere with the safe and proper construction, operation, and maintenance of any said utility system on the Easement Tracts or which creates hazardous conditions, and to keep the Easement Tracts clear of such obstacles and obstructions. The City shall have the right to clear and remove any such obstacles, but not the obligation to do so.

Subsequent owners may make any use of the Easement Tracts, so long as such use does not interfere with the rights herein reserved or create a hazardous condition, except that the subsequent owners shall make no excavations on the Easement Tracts without the prior consent of the City and then only in such manner as will not disturb or interfere with the City's facilities located therein, nor shall the subsequent owners place buildings or structures on the

Easement Tracts. Subsequent owners may pave entranceways over the Easement Tracts. Notwithstanding the contrary in this Easement, the City shall not interfere with any ingress or egress over or upon any roadways on the said Easement Tracts.

IN WITNESS WHEREOF, we have hereunto set our hand and seal this _____ day of _____, A.D., _____.

Designated Representative
City of Peru

NOTARY PUBLIC

STATE OF ILLINOIS)
COUNTY OF LASALLE) SS

I, _____, a Notary Public in and for said County, in the State aforesaid, do hereby certify that the City of Peru, Designated Representative personally known to me to be the Owner, whose name is subscribed to the foregoing instrument, appeared before me this day in person and severally acknowledged that as such, he/she signed and delivered the said instrument of writing as their and voluntary act and deed, for the uses and purposes set forth.

Given under my hand and notarial seal this _____ day of _____, A.D., _____.

Notary Public

SCHOOL DISTRICT CERTIFICATE

STATE OF ILLINOIS)
COUNTY OF LASALLE) SS

We, the City of Peru, Designated Representative, Owner of the property herein described in the Surveyor's Certificate, do hereby certify that "Halm Subdivision, City of Peru, Illinois," to the best of our knowledge, is located within the boundaries of Dimmick Comm. Cons. School District #175, LaSalle-Peru Township High School #120, and Illinois Valley Community College School District #513 in LaSalle County, Illinois.

Dated this _____ day of _____, A.D., _____.

Designated Representative

IDOT CERTIFICATE

This plat has been approved by the Illinois Department of Transportation with respect to roadway access pursuant to 765 ILCS 205/2, as amended. However, a Highway Permit for access is required by the Owner of the property. A plan that meets the requirements contained in the Department's "Policy on Permits for Access Driveways to State Highways" will be required by the Department.

Date: _____

Region 2 Engineer

CITY CERTIFICATES

STATE OF ILLINOIS)
COUNTY OF LASALLE) SS
CITY OF PERU)

Approved and accepted by the Council of the City of Peru, this _____ day of _____, A.D., _____, by Ordinance No. _____ on file with the City Clerk of Peru, Illinois, entitled "An Ordinance Approving the Plat of "Halm Subdivision, City of Peru, Illinois" as follows:

BE IT ORDAINED BY THE CITY COUNCIL OF THE CITY OF PERU, LASALLE COUNTY, ILLINOIS, A HOME RULE MUNICIPALITY, AS FOLLOWS:

Section 1: That the plat of the Halm Subdivision, City of Peru, Illinois, as made by Michael S. Richetta, Professional Land Surveyor, under and by direction of the City of Peru of the premises described and platted herein, and the same is hereby approved and accepted.

Section 2: That this Ordinance shall be in full force and effect from and after its passage and approval thereof.

The above Ordinance was adopted at a meeting of the City Council of the City of Peru, Illinois, held on the _____ day of _____, A.D., _____, with _____ Aldermen voting "Aye" and _____ Aldermen voting "Nay" and the Mayor voting _____.

Jamey Mertel, City Clerk
City of Peru, Illinois

Approved by the Mayor of the City of Peru this _____ day of _____, A.D., _____.

Kenneth Kolowski, Mayor
City of Peru, Illinois

Approved by the Planning/Zoning Commission of the City of Peru, Illinois, on the _____ day of _____, A.D., _____.

Chairman
STATE OF ILLINOIS)
COUNTY OF LASALLE) SS
CITY OF PERU)

I, Jamey Mertel, City Clerk of the City of Peru, Illinois, do hereby certify that there are no unpaid special assessments or special taxes levied against the tract of land or any part thereof in the plat on which this Certificate is attached.

Dated this _____ day of _____, A.D., _____.

Jamey Mertel, City Clerk
City of Peru, Illinois

COUNTY CERTIFICATE

STATE OF ILLINOIS)
COUNTY OF LASALLE) SS

I, Jennifer Ebner, County Clerk of LaSalle County, Illinois, do hereby certify that I have examined the record of said County, that I find no delinquent general taxes, unpaid current general taxes, delinquent special assessments or unpaid current special assessments against the tract of land, or any part thereof, in the plat to which this is attached.

Given under my hand and official seal this _____ day of _____, A.D., _____.

Jennifer Ebner, County Clerk

TAX CODE NO(S): 11-77-333-001, 11-77-433-001

 Chamlin & Associates ENGINEERS • SURVEYORS • PLANNERS	4152 Progress Blvd Peru, IL 61354 815.223.3344 www.chamlin.com Professional Design Firm License # 184-001717 © Copyright 2025 All Rights Reserved	<h2 style="margin: 0;">FINAL PLAT</h2> <p style="margin: 0;">BEING A PART OF THE SOUTH HALF OF SECTION 33, T. 34 N., R. 1 E. OF THE 3RD P.M.</p>	DATE: 10/15/2025 FIELDWORK: 08/2025 REVISED: DRAWN BY: LAG CHECKED BY: MSR JOB NUMBER: 15553.00
	PREPARED FOR: CITY OF PERU	SHEET 2 OF 2	



Post Office Box 299
Peru, Illinois 61354

October 16, 2025

Mayor Ken Kolowski,
Peru City Clerk, and
Aldermen of the City of Peru

RE: Petition of Sabas Oraldo Madera and Ana Rosa Madera
2404 Plum Street, Peru, IL (PIN: 17-09-318-008)

Gentlemen:

Pursuant to legal notice published in the News Tribune in the manner provided by law, the Planning/Zoning Commission of the City of Peru convened for a public hearing on Wednesday, October 15, 2025, at 5:00 p.m. in the City Municipal Building, 1901 Fourth Street, Peru, IL, to consider the Petition of Sabas Oraldo Madera and Ana Rosa Madera (“Petitioners”) concerning property commonly known as 2404 Plum Street in the City of Peru, Illinois, legally described as follows:

Lot Fifty-Three in Marquette Manor Addition to the City of Peru, LaSalle County, Illinois, excepting coal and mining rights as heretofore conveyed and subject to restrictions contained in a Declaration of Restrictions dated March 25, 1959, filed in the Office of the Recorder of Deeds of LaSalle County, Illinois on April 3, 1959 and recorded in Book 1117 of the Records, situated in the County of LaSalle, in the State of Illinois.

PIN: 17-09-318-008 (“Property”)

Petitioners desire to construct a new fence on the Property and seek the following relief under the Zoning Ordinance, to wit:

- (1) A special use pursuant to Section 10.03(c)(8) to allow fencing in a side yard abutting 24th Street;
- (2) A variance to reduce the minimum side yard setback abutting 24th Street for a fence from not less than 30’, as provided in Sections 6.03(b)(5) and 10.03(h)(2), to not less than 0’; and
- (3) For such other and further relief deemed necessary or appropriate.

The Property is zoned R-2 Single Family, Detached Dwelling District.

Planning/Zoning Commission Members Lucas, Jones, Grabowski, and Brady were present at the hearing. Chairman Miller and Members Kalsto and Becker were absent.

Petitioners Sabas Oraldo Madera and Ana Rosa Madera appeared and were duly sworn. Ms. Madera testified that they would like to extend the existing fence in the rear yard south to the Property line, east along 24th Street, then north to connect back in line with the front of the home.

In response to questioning from Member Brady, Ms. Madera stated the fence would 6' tall and set back 16' from the roadway pavement.

In response to questioning from Corporation Counsel Schweickert, Ms. Madera testified that Petitioners have a special needs son and the additional enclosed yard space would provide him with a safe space. In the future, they will contemplate possibly getting a dog or above ground pool as well. In response to further questioning from Attorney Schweickert, Ms. Madera stated that Petitioners did have their property line pins located and the fence would constructed be on the property line.

City Director of Engineering and Zoning, Eric Carls noted it is a tight area and he did not have any concerns.

There were no public comments or objections.

The Planning/Zoning Commission found the requested relief will not alter the essential character of the locality; will not be detrimental or injurious to other properties in the area; will not impair an adequate supply of light or air to adjacent properties, or increase the danger of fire, or endanger the public safety, or diminish or impair property values and will not increase street congestion and, therefore, favorably recommends that the City Council grant the relief as prayed for in the Petition.

Member Lucas moved, and Member Brady seconded, to favorably recommend that the City Council approve the Petition as prayed for. The motion passed unanimously: 4 aye, 0 nay, and 3 Members absent.

Respectfully submitted,

CARY MILLER, Chairman
Planning/Zoning Commission

ORDINANCE NO _____

AN ORDINANCE GRANTING A SPECIAL USE AND VARIANCE AS SOUGHT BY THE PETITION OF SABAS ORALDO MADERA AND ANA ROSA MADERA CONCERNING PROPERTY LOCATED AT 2404 PLUM STREET IN THE CITY OF PERU.

WHEREAS, after legal ad notice duly published in the News Tribune in the manner provided by law, the Planning/Zoning Commission of the City of Peru conducted a public hearing on October 15, 2025, to consider the Petition of Sabas Oraldo Madera and Ana Rosa Madera (“Petitioners”) concerning property located at 2404 Plum Street in the City of Peru, Illinois, legally described as follows:

Lot Fifty-Three in Marquette Manor Addition to the City of Peru, LaSalle County, Illinois, excepting coal and mining rights as heretofore conveyed and subject to restrictions contained in a Declaration of Restrictions dated March 25, 1959, filed in the Office of the Recorder of Deeds of LaSalle County, Illinois on April 3, 1959 and recorded in Book 1117 of the Records, situated in the County of LaSalle, in the State of Illinois.

PIN: 17-09-318-008 (“Subject Property”); and

WHEREAS, Petitioners desire to construct a new fence on the Subject Property and seek the following relief under the Zoning Ordinance, to wit:

- (1) A special use pursuant to Section 10.03(c)(8) to allow fencing in a side yard abutting 24th Street;
- (2) A variance to reduce the minimum side yard setback abutting 24th Street for a fence from not less than 30’, as provided in Sections 6.03(b)(5) and 10.03(h)(2), to not less than 0’;

and

WHEREAS, the Planning/Zoning Commission has made its report of hearing and has unanimously recommended that the City Council approve the relief as sought by Petitioners.

NOW, THEREFORE, BE IT ORDAINED BY THE CITY COUNCIL OF THE CITY OF PERU, ILLINOIS, A HOME RULE MUNICIPALITY, AS FOLLOWS:

SECTION 1: The City Council finds as facts the recitals hereinbefore set forth and incorporates them herein by reference.

SECTION 2: The Subject Property is hereby granted a special use pursuant to Section 10.03(c)(8) of the Zoning Ordinance to allow fencing in the side yard abutting 24th Street, and a

variance to reduce the minimum side yard setback abutting 24th Street for a fence from not less than 30', as provided in Sections 6.03(b)(5) and 10.03(h)(2) of the Zoning Ordinance, to not less than 0'.

The relief granted herein shall be for the sole purpose of constructing a fence upon the Subject Property in accordance with plans on file with the City. Nothing in this Ordinance shall be construed to preempt any private covenants and restrictions that may be applicable to the Subject Property.

SECTION 3: This Ordinance shall be in full force and effect from and after its passage and approval according to law.

PRESENTED, PASSED, AND ADOPTED at a regular meeting of the City Council of the City of Peru, Illinois, by an aye and nay roll call vote, with _____ voting aye, _____ voting nay, _____ absent, and Mayor Kolowski _____ voting _____, which meeting was held on the 20th day of October, 2025.

APPROVED: October 20, 2025

Ken Kolowski, Mayor

(CORPORATE SEAL)

ATTEST:

Jamey Mertel
City Clerk

<u>Aldermen</u>	<u>Aye</u>	<u>Nay</u>	<u>Absent</u>
Ballard			
Tieman			
Payton			
Edgcomb			
O'Sadnick			
Sapienza			
Lukosus			
Moreno			



Post Office Box 299
Peru, Illinois 61354

October 16, 2025

Mayor Ken Kolowski,
Peru City Clerk, and
Aldermen of the City of Peru

RE: Petition of Kevin and Jessica Mateika
2103 Main Street, Peru, IL (PIN: 17-17-457-013)

Gentlemen:

Pursuant to legal notice published in the News Tribune in the manner provided by law, the Planning/Zoning Commission of the City of Peru convened for a public hearing on Wednesday, October 15, 2025, at 5:00 p.m. in the City Municipal Building, 1901 Fourth Street, Peru, IL, to consider the Petition of Kevin and Jessica Mateika (“Petitioners”) concerning property commonly known as 2103 Main Street in the City of Peru, Illinois, legally described as follows:

The South Half (S ½) of Lot Ten (10) in Block Eighty-three (83) in Ninewa Addition to the Town, now City of Peru, situated in the County of LaSalle and the State of Illinois, except coal and minerals and the right to mine and remove the same.

PIN: 17-17-457-013 (“Property”)

Petitioners desire to construct a [345 sq. ft. ground floor area], two-story addition, comprised of a garage and additional 2nd story living space, to the existing dwelling on the Property and seek the following relief under the Zoning Ordinance, to wit:

(1) A special use and variance to reduce the minimum interior side yard setback from not less than 10’, as provided in Sections 10.03(c)(11) and 10.03(h)(1), to not less than 1’; and

(2) For such other and further relief deemed necessary or appropriate.

The Property is zoned R-2 Single Family, Detached Dwelling District.

Planning/Zoning Commission Members Lucas, Jones, Grabowski, and Brady were all present at the hearing. Chairman Miller and Member Kalsto and Becker were absent.

Petitioner, Kevin Mateika appeared and was duly sworn. Mr. Mateika testified that Petitioners would like to construct a 15' wide garage. He stated the back yard is already a concrete patio and the addition will not extend further than the existing footprint of that concrete or will be in-line with the rear line of the home. The addition will be one foot inside the existing fence line to the north. Mr. Mateika said they are in need of a garage and want to make the house their forever home.

Mr. Mateika testified further that Petitioners had spoken to their affected neighbors to the north and they had no objection. A letter of approval signed by the neighbors was received into the record and a copy is attached.

In response to questioning from Member Grabowski, Mr. Mateika said they would remove the existing concrete patio and pour a new foundation for the addition.

In response to questioning from Member Lucas, Mr. Mateika confirmed the ground area footprint of the addition is 15' x 23', or 345 sq. ft. It was noted that the published notice erroneously had 1,425 sq. ft. Mr. Mateika said they would be taking off the stucco and ripping the whole north side of the house off, then adding to it and extending the roof.

City Director of Engineering and Zoning, Eric Carls, noted the Property was situated on a smaller lot typical of the surrounding area and stated he did not necessarily have an issue with the request. He noted the existing patio area is going to be enclosed with a garage and provide additional living space on the second floor. Carls said he had no concerns.

There were no public comments or objections.

The Planning/Zoning Commission found the requested relief will not alter the essential character of the locality; will not be detrimental or injurious to other properties in the area; will not impair an adequate supply of light or air to adjacent properties, or increase the danger of fire, or endanger the public safety, or diminish or impair property values and will not increase street congestion and, therefore, favorably recommends that the City Council grant the relief as prayed for in the Petition.

Member Brady moved, and Member Grabowski seconded, to favorably recommend that the City Council approve the Petition as prayed for. The motion passed unanimously: 4 aye, 0 nay, and 3 Members absent.

Respectfully submitted,

CARY MILLER, Chairman
Planning/Zoning Commission

08/31/2025

We, Dennis & Melony Nowatka, agree to have our neighbors, Kevin & Jessica Mateika, build an attached structure that would come within 1 foot of our shared property line. The existing property line is 17 feet from their existing home. The new structure will be 15 feet wide and 23 and a half feet deep, which matches the depth of their existing home. The new structure will be a two-story structure. The bottom of the structure will be an attached garage with attached living space in the second story. The roof line will match the existing roof line so that no more rain will be forced in that direction and will have gutters put on as well. The main structure itself will stay two feet from the property line but the extra foot is to account for any overhang of roof or siding. With that being said the total of the structure including any overhang will be at least 1 foot from our shared property line if not more.

By signing we are stating that we are in agreement with the terms stated above.

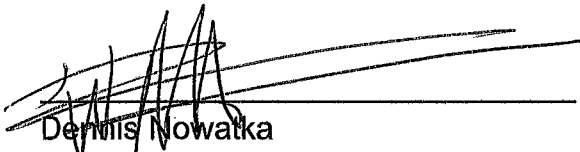

Dennis Nowatka



Melony Nowatka



Kevin Mateika

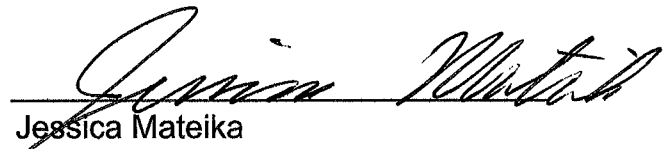

Jessica Mateika

ORDINANCE NO _____

AN ORDINANCE GRANTING A SPECIAL USE AND VARIANCE AS SOUGHT BY THE PETITION OF KEVIN AND JESSICA MATEIKA CONCERNING PROPERTY LOCATED AT 2103 MAIN STREET IN THE CITY OF PERU.

WHEREAS, after legal ad notice duly published in the News Tribune in the manner provided by law, the Planning/Zoning Commission of the City of Peru conducted a public hearing on October 15, 2025, to consider the Petition of Kevin and Jessica Mateika (“Petitioners”) concerning property located at 2103 Main Street in the City of Peru, Illinois, legally described as follows:

The South Half (S ½) of Lot Ten (10) in Block Eighty-three (83) in Ninewa Addition to the Town, now City of Peru, situated in the County of LaSalle and the State of Illinois, except coal and minerals and the right to mine and remove the same.

PIN: 17-17-457-013 (“Subject Property”); and

WHEREAS, Petitioners desire to construct a 345 sq. ft. ground floor area, two-story addition comprised of a garage and additional 2nd story living space to the existing dwelling on the Subject Property and seek a special use and variance to reduce the minimum interior side yard setback from not less than 10’, as provided in Sections 10.03(c)(11) and 10.03(h)(1) the Zoning Ordinance, to not less than 1’; and

WHEREAS, the Planning/Zoning Commission has made its report of hearing and has unanimously recommended that the City Council approve the relief as sought by Petitioners.

NOW, THEREFORE, BE IT ORDAINED BY THE CITY COUNCIL OF THE CITY OF PERU, ILLINOIS, A HOME RULE MUNICIPALITY, AS FOLLOWS:

SECTION 1: The City Council finds as facts the recitals hereinbefore set forth and incorporates them herein by reference.

SECTION 2: The Subject Property is hereby granted a special use as provided in Section 10.03(c)(11) and a variance as provided in Section 10.03(h)(1) of the Zoning Ordinance to reduce the minimum interior side yard setback from not less than 10’, to not less than 1’.

The relief granted herein shall be for the sole purpose of constructing an addition to the existing dwelling upon the Subject Property in accordance with plans on file with the City. Nothing

in this Ordinance shall be construed to preempt any private covenants and restrictions that may be applicable to the Subject Property.

SECTION 3: This Ordinance shall be in full force and effect from and after its passage and approval according to law.

PRESENTED, PASSED, AND ADOPTED at a regular meeting of the City Council of the City of Peru, Illinois, by an aye and nay roll call vote, with _____ voting aye, _____ voting nay, _____ absent, and Mayor Kolowski _____ voting _____, which meeting was held on the 20th day of October, 2025.

APPROVED: October 20, 2025

Ken Kolowski, Mayor

(CORPORATE SEAL)

ATTEST:

Jamey Mertel
City Clerk

<u>Aldermen</u>	<u>Aye</u>	<u>Nay</u>	<u>Absent</u>
Ballard			
Tieman			
Payton			
Edgcomb			
O'Sadnick			
Sapienza			
Lukosus			
Moreno			

ORDINANCE NO. _____

AN ORDINANCE AUTHORIZING THE ACCEPTANCE OF A PUBLIC UTILITY EASEMENT FROM PERU INDUSTRIAL RAILROAD, LLC
(Peru Rail f/k/a LaSalle & Bureau County Railway, Peru – GIS PIN: 11-32-502-001)

WHEREAS, the City of Peru, an Illinois home rule municipal corporation (hereinafter, “City”), proposes certain utility improvements, namely the construction of a new watermain loop between Unytite Drive and North 31st Road in the City of Peru to improve the reliability of water service to industrial users in that area; and

WHEREAS, in order to construct said improvements, there is a need to obtain a Public Utility Easement from Peru Industrial Railroad, LLC, a Colorado limited liability company (hereinafter, “PIR”) to cross the railroad PIR owns and operates, and PIR has agreed to provide the City with said Public Utility Easement, a copy of which is attached hereto and made a part hereof; and

WHEREAS, the acquisition of the Public Utility Easement is a matter pertaining to the government and affairs of the City, is for a proper public purpose, and is in the best interests of the health, safety, and welfare of the City.

NOW, THEREFORE, BE IT ORDAINED BY THE CITY COUNCIL OF THE CITY OF PERU, ILLINOIS, A HOME RULE MUNICIPALITY, AS FOLLOWS:

SECTION 1: The Mayor, for and on behalf of the City, is hereby authorized and directed to execute and accept, and the City Clerk, for and on behalf of the City, is hereby authorized and directed to attest, the attached Public Utility Easement from PIR.

SECTION 2: This Ordinance shall be effective immediately from and after its passage and approval as provided by law.

PRESENTED, PASSED, AND ADOPTED at a regular meeting of the City Council of the City of Peru, Illinois, by an aye and nay roll call vote, with __ voting aye, __ voting nay, __ absent, and Mayor Kolowski _____ voting _____, which meeting was held on the 20th day of October, 2025.

APPROVED: October 20, 2025

Ken Kolowski, Mayor

(CORPORATE SEAL)

ATTEST:

Jamey Mertel
City Clerk

<u>Aldermen</u>	<u>Aye</u>	<u>Nay</u>	<u>Absent</u>
Ballard			
Tieman			
Payton			
Edgcomb			
O'Sadnick			
Sapienza			
Lukosus			
Moreno			

PUBLIC UTILITY EASEMENT

This space reserved for Recorder's use only.

This Easement (hereinafter, "Easement") is made between Peru Industrial Railroad, LLC, a Colorado limited liability company (hereinafter, "Railroad"), and the City of Peru, an Illinois home rule municipal corporation (hereinafter, "City").

In consideration of the mutual covenants and agreements herein contained and other good and valuable consideration, Railroad and the City agree as follows:

1. **Grant.** Railroad hereby grants a perpetual easement to the City to construct, install, use, maintain, repair, and operate, a 11.1" (inch) potable water PVC pipeline within a 24" (inch) steel casing pipe (hereinafter, the "Pipe Line") in, over, across, and along the real estate described and depicted on Exhibit "A", attached hereto and incorporated herein (hereinafter, the "Easement Tract"). The term Pipe Line shall be deemed to be the actual lines and any and all appurtenances in so far as they relate to the Pipe Line within the location of the Easement Tract.

2. **Payment.** The City shall pay to Railroad, without prejudice to any rights of the City, the sum of Ten Dollars (\$10.00).

3. **Specifications.**

A. The Pipe Line shall be constructed, installed, used, maintained, repaired, and operated in strict accordance with any and all current requirements and specifications adopted by the American Railway Engineering and Maintenance of Way Association, and in compliance with any and all laws, statutes, regulations, or order of any federal, state, or municipal governmental body or any agency thereof or created thereby. All materials and workmanship employed in the construction, installation, use, maintenance, repair and operation of the Pipe Line shall be subject to the approval of Railroad Chief Engineer authorized representative, which approval shall not be unreasonably delayed or denied. Railroad acknowledges that the initial construction plans of the Pipe Line have been approved.

- B. The City shall require each of its contractors and subcontractors to observe and conform to the conditions and requirements specified herein.
- C. The City shall, at no expense to Railroad, obtain all permits and approvals required to exercise this Easement and the City shall install, maintain and operate its facilities in accordance with all requirements of lawful public authority. The City shall be responsible for any taxes, assessments and charges made against the Pipe Line for any of the City's facilities on the Easement Tract or the operation of any of them.
- D. During City's construction, installation, maintenance or repair of the Pipe Line, Railroad shall have the right, but not the duty, to furnish flagging or other protection or to perform work to support its tracks or otherwise protect its properties or facilities at the City's reasonable and necessary expense.

4. **Insurance.** The City shall purchase and maintain insurance for the Pipe Line and all work and services to be performed hereunder with reputable insurance companies with the following coverages and limits:

- A. Workers' Compensation Employers Liability insurance providing workers' compensation benefits mandated under applicable State law and employers' liability insurance subject to a minimum limit of \$1MM for each accident for bodily injury by accident; \$1MM for each employee for bodily injury by disease, and \$1MM policy limit for bodily injury by disease.
- B. Commercial General Liability Insurance written on an occurrence basis subject to limit of \$1MM each occurrence for bodily injury, property damage, personal injury, and advertising injury with an annual aggregate limit of no less than \$2MM. Policy coverage is to be based on usual Insurance Services Office (hereinafter "ISO") policy forms to include, but not be limited to: operations and premises liability, products liability, personal injury liability, and contractual liability insurance.
- C. Business automobile liability insurance subject to a minimum of \$1MM for each accident for bodily injury, property damage, personal injury, and advertising injury.

5. **Waiver.** This Easement is made without covenant on the part of Railroad to warrant its title to the property involved for said Easement, or to give or defend the City in the peaceable possession of said property, and the City waives all right to claim damages in the event the City shall be evicted, ejected, or required to surrender possession of the property by anyone owning or claiming title to, or an interest in the property, or by reason of failure of title of Railroad, or for any other cause.

6. **Repairs and Relocation.** The City will at all times maintain the Pipe Line in a safe and secure manner and in a condition satisfactory to Railroad's authorized representative. Railroad may request the City to make reasonable repairs or changes necessary in order to avoid interference with or danger in the operation of Railroad's railroad.

7. **Miscellaneous.**

- A. The personal pronouns used herein as referring to City shall be understood so to refer to the City whether the City be a natural person (one or more), a partnership, a corporation, or any combination thereof, and all the covenants and agreements contained herein shall be the joint and several covenants and agreements of all such parties.
- B. Any notices hereunder to be given by Railroad to City shall be deemed to be properly given if, served upon or delivered to City or its authorized representative, or if deposited in the U.S. mail, postage prepaid and addressed to the City at the address listed below. Any notice hereunder to be given to Railroad by City shall be deemed to be properly given if the same be deposited in the U.S. mail postage prepaid, addresses as below:

Railroad: Peru Industrial Railroad, LLC
Attn: Real Estate
252 Clayton Street, 4th Floor
Denver, Colorado 80206

City: City of Peru
Attn: Corporation Counsel
1901 Fourth Street
P.O. Box 299
Peru, IL 61354

- C. No oral promises, oral agreements, or oral warranties shall be deemed a part of this Easement, nor shall any alteration, amendment, supplement or waiver of any of the provisions of this Easement be binding upon either party hereto, unless same be supplemented, altered, changed or amended by an instrument in writing, signed by Railroad and the City.
- D. All obligations of the City hereunder to protect, indemnify and hold harmless Railroad shall also extend to members, managers, directors, officers, shareholders, employees and/or contractors of Railroad, and to companies and other legal entities that control, are controlled by, are subsidiaries of or affiliated with Railroad, its officers, managers, agents, employees, members, directors, shareholders, and/or contractors.
- E. This Easement is made subject to the rights granted by or through Railroad for any surface, subsurface or aerial uses antedating this Easement, including but not limited to, the construction, maintenance, operation, renewal, and/or relocation of fences, pipelines, communication lines, power lines, railroad tracks and signals, and any and all appurtenances applicable thereto. Railroad accepts and reserves the right to grant additional uses of the same or similar nature subsequent to the execution of this Easement, without payment of any sum for damages, so long as such use does not unreasonably interfere with the use of the Easement by the City.

- F. This Easement and all of the provisions herein contained shall be binding upon the parties hereto, their heirs, executors, administrators, successors and assigns, and the City agrees to supply notice in writing to Railroad of any name changes. The City agrees not to assign this Easement or any interest therein, without the consent of Railroad in writing, which consent shall not be unreasonably withheld, and any and every attempted assignment without prior written consent shall be void and of no effect. In the event of any assignment, the City shall at all times remain fully responsible and liable for the compliance of all of its obligations under the terms, provisions and covenants.
- G. Nothing in this Easement shall be construed to place any responsibility on Railroad for the quality of the construction, maintenance or other work performed on behalf of the City hereunder or for the condition of any of City's facilities.
- H. Any approval given or supervision exercised by Railroad hereunder, or failure of Railroad to object to any work done, material used or method of construction, reconstruction or maintenance, shall not be construed to relieve the City of its obligations under this Easement.
- I. All exhibits attached hereto are incorporated as if fully set forth herein.
- J. The City further indemnifies Railroad against any and all liens that may be placed against Railroad's property as a result of construction of the Pipe Line and agrees to immediately satisfy any liens so placed.
- K. This Easement shall be governed under the laws of the State of Illinois and venue shall be proper in the state courts of the State of Illinois for any action arising under the terms of this Easement or performance thereof.

IN WITNESS WHEREOF, the parties have executed this Easement as of the last date of execution set forth below:

**Peru Industrial Railroad, LLC,
a Colorado limited liability company**

**CITY OF PERU, an Illinois
home rule municipal corporation**

By: 

By: _____

Name: Carl D. Kroger

Name: _____

Title: Authorized Signatory

Title: _____

Date: 10/16/25

Date: _____

STATE OF Colorado)
) SS
COUNTY OF Denver)

I, the undersigned, a Notary Public in and for said County, in the State aforesaid, do hereby certify that Carl D. Kroger, personally known to me to be the Authorized Signatory of PERU INDUSTRIAL RAILROAD, LLC, a Colorado limited liability company, and personally known to me to be the same person whose name is subscribed to the foregoing instrument, appeared before me this day in person and severally acknowledged under oath that as such Authorized Signatory, he/she signed and delivered the said instrument pursuant to authority given by the Operating Agreement of said limited liability company as his/her voluntary act, and as the free and voluntary act and deed of said limited liability company, for the uses and purposes therein set forth.

Given under my hand and notarial seal this 16th day of October, A.D., 2025.



Karin Rita West
Notary Public

ACCEPTANCE

The above and foregoing Public Utility Easement is accepted by the City of Peru, Illinois, pursuant to direction of its City Council, this _____ day of _____, 2025.

**CITY OF PERU, an Illinois
home rule municipal corporation**

BY: _____
Ken Kolowski, Mayor

(CORPORATE SEAL)

ATTEST:

Jamey Mertel, City Clerk

After Recording Return To:
City of Peru, Illinois
ATTN: Corporation Counsel
1901 Fourth Street
Peru, IL 61354
TEL (815) 224-6020
FAX (815) 223-9381

EASEMENT EXHIBIT
 FOR
PERMANENT PUBLIC UTILITY EASEMENT
PART OF THE SW 1/4 OF SECTION 32
T. 34 N., R. 1 E., 3RD P.M.
LASALLE COUNTY, ILLINOIS
MAY, 2025

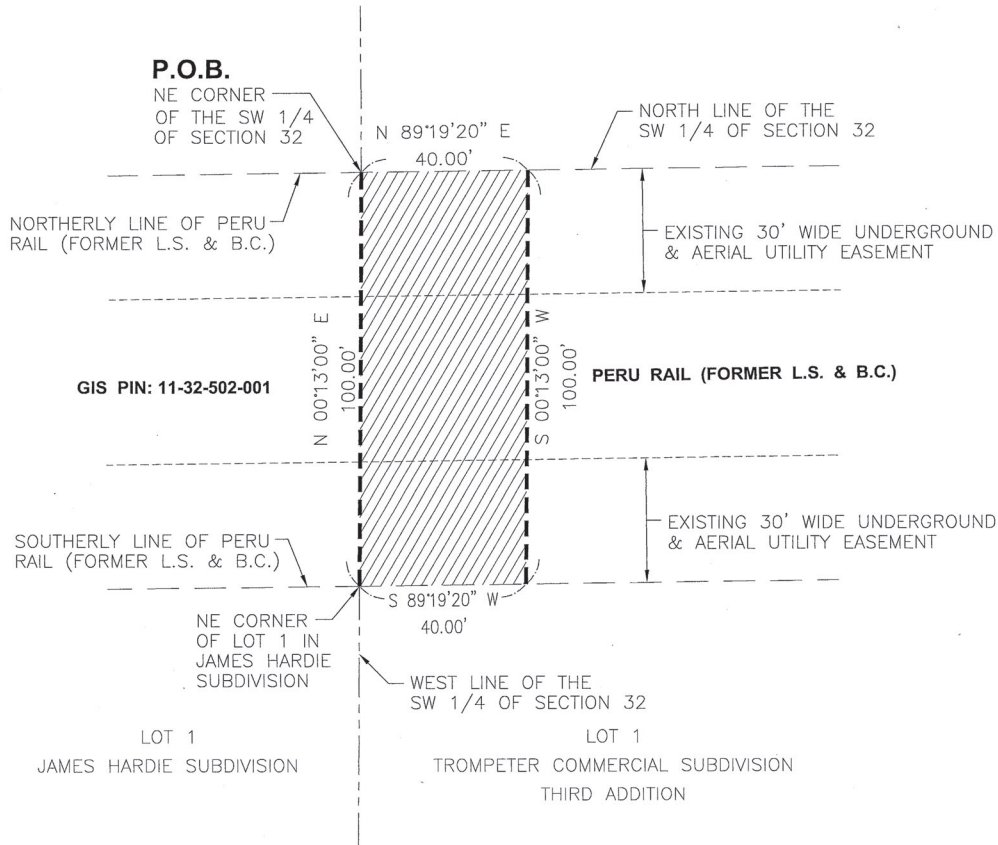
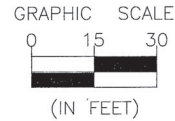

LEGEND

- PERMANENT PUBLIC UTILITY EASEMENT
- EXISTING RIGHT OF WAY LINE
- EXISTING SECTION LINE
- EXISTING EASEMENT
- P.O.B.** POINT OF BEGINNING



expires 11-30-2026
 PROFESSIONAL DESIGN FIRM
 LICENSE NO. 184-001717
 miker@chamlin.com

I, MICHAEL S. RICHETTA, HEREBY CERTIFY THAT THIS DOCUMENT WAS PREPARED UNDER MY DIRECTION

ILL. PLS NO. 035-003788

DATE 6/2/2025

CHAMLIN & ASSOCIATES, INC. © 2025
 Drawing Name: G:\Users\g\99070-00-Peru Watermain Ext to Eokas\CAD\EASEMENT PLATS\Y2-EASE-RR.dwg Last Modified: May 28, 2025 - 8:07am Plotted on: Jun 02, 2025 - 10:28am by lpawelczyk



PERU OTTAWA MORRIS
 ILLINOIS

EXHIBIT
A

PERMANENT PUBLIC UTILITY EASTMENT

LEGAL DESCRIPTION

Beginning at the Northeast Corner of the Southwest Quarter of Section 32, Township 34 North, Range 1 East of the Third Principal Meridian, said point also being on the Northerly Line of Peru Rail (Former L. S. & B. C.); thence North 89 degrees 19 minutes 20 seconds East 40.00 feet along said Northerly Line and the North Line of said Southwest Quarter; thence South 00 degrees 13 minutes 00 seconds West 100.00 feet to the Southerly Line of said Peru Rail; thence South 89 degrees 19 minutes 20 seconds West 40.00 feet along said Southerly Line to the West Line of said Southwest Quarter; thence North 00 degrees 13 minutes 00 seconds East 100.00 feet along said West Line to the Point of Beginning. Situated in the County of LaSalle and State of Illinois.

ORDINANCE NO. _____

AN ORDINANCE DECLARING A CERTAIN POLICE DEPARTMENT SQUAD CAR AS SURPLUS PROPERTY AND AUTHORIZING THE SALE THEREOF

WHEREAS, the City of Peru, Illinois (“City”), is a home rule unit of government and pursuant to Article 7, Section 6(a), of the 1970 Constitution of the State of Illinois, may exercise any power and perform any function pertaining to its government and affairs; and

WHEREAS, the Illinois Municipal Code, 65 ILCS 5/11-76-4, grants municipalities with a population less than 500,000 the authority to dispose of personal property it determines by a simple majority of the corporate authorities to be no longer necessary or useful to, or for the best interests of the City; and

WHEREAS, the Mayor and City Council find and determine that the City’s continued ownership of the following Police Department squad car is no longer necessary or useful to, or for the best interests of, the City and hereby declares the same as surplus personal property:

VEHICLE					
<u>ID#</u>	<u>YEAR</u>	<u>MAKE</u>	<u>MODEL</u>	<u>MILEAGE</u>	<u>V.I.N.</u>
42	2014	Ford	Interceptor Sedan		1FAHP2MK9EG178662

(hereinafter, the “Surplus Property”); and

WHEREAS, the Village of Cherry has expressed an interest and desire to purchase the Surplus Property for use by the Village’s Police Department for the purchase price of \$6,000.00; and

WHEREAS, the Corporate Authorities of the City of Peru desire to authorize and approve the sale of the Surplus Property to the Village of Cherry for \$6,000.00

NOW, THEREFORE, BE IT ORDAINED BY THE CITY COUNCIL OF THE CITY OF PERU, ILLINOIS, A HOME RULE MUNICIPALITY, AS FOLLOWS:

SECTION 1: Recitals. The City Council finds as facts the recitals hereinbefore set forth and incorporates them herein by reference.

SECTION 2: Sale of Surplus Property by Auction. Pursuant to 65 ILCS 5/11-76-4, the City’s Chief of Police, Sarah Raymond, or her designee is hereby authorized and directed to sell the Surplus Property to the Village of Cherry for the purchase price of \$6,000.00. The Mayor, City Clerk, and Chief of Police are further authorized to execute all documents and take

all actions necessary to sell, convey, and transfer ownership of the Surplus Property to the Village of Cherry in exchange for payment in full of the purchase price.

SECTION 3. Effective Date. This Ordinance shall be effective immediately from and after its passage and approval.

PRESENTED, PASSED, AND ADOPTED at a regular meeting of the City Council of the City of Peru, Illinois, by an aye and nay roll call vote, with _____ voting aye, _____ voting nay, _____ absent, and Mayor Kolowski _____ voting _____, which meeting was held on the 20th day of October, 2025.

APPROVED: October 20, 2025

Ken Kolowski, Mayor

(CORPORATE SEAL)

ATTEST:

**Jamey Mertel
City Clerk**

<u>Aldermen</u>	<u>Aye</u>	<u>Nay</u>	<u>Absent</u>
Ballard			
Tieman			
Payton			
Edgcomb			
Sapienza			
O'Sadnick			
Lukosus			
Moreno			